

AKR 800



USER MANUAL

CONTENTS

I. INTRODUCTION	6
II. DIRECTION FOR USE	8
1. Intended use	9
a. Intended purpose	9
b. Indications for use	9
2. Expected clinical benefit	9
3. Contraindications	9
4. Side effects	9
5. Intended population	9
6. Intended users	9
III. CAUTIONS AND WARNINGS	10
1. Definitions	11
2. Product safety	12
a. Unpacking & Storage	12
b. Precautions on IT Network	12
c. Specific considerations regarding electrical safety	13
d. Patient environment	13
e. Warning labels on the device	14
IV. PRODUCT DESCRIPTION	15
1. Product plan with description	16
a. Main unit	16
b. Operations on control panel	16
2. Description of LCD touch panel	17
a. Measurement mode	17
b. Measurement mode - P.K	19
c. Measurement mode - R-SMP	19
d. Measurement mode - WTW	20
e. Measurement mode - Accommodation (optional feature, only available on the AKR800NV commercial offer)	21
f. Measurement mode - Retro Illumination (optional feature, only available on the AKR800NV commercial offer)	22
3. List of accessories	22
V. OPERATING INFORMATION	24
1. Installation of the device	25
a. Unpacking method of internal packing box	25
b. Connection of power cord	26
c. Connection of external input/output terminal	26
d. Setting of printer paper	27
e. Return from sleep mode	28
2. Turning On/Off the device	28
a. Turning ON	28
b. Turning OFF	28
3. Connection to other instruments	28
VI. USE OF THE DEVICE	29
1. Flow operation	30
2. Setting of patient information	31
3. Preparation of examinee	32

4. Alignment and Measurement	33
5. Confirmation of measurement result	35
6. Print out and external output of measurement result	37
7. Measurement of the other eye	37
8. Measurement and analysis result	38
a. Printer output content	38
b. Description of report output	39
9. Operation after measurement	39
10. Optional function measurement method	40
a. [P.K]	40
b. [R-SMP]	43
c. [WTW]	46
d. Accommodation (optional feature, only available on the AKR800NV commercial offer)	47
e. Retro Illumination (optional feature, only available on the AKR800NV commercial offer)	48
VII. SETTING OF FUNCTION ON [SETUP] SCREEN	51
1. Operation Procedure on [Setup] screen	52
2. List of setup items	52
3. [Setup] screen - [Measure] tab	53
a. [Setup] screen - [Measure 1]	53
b. [Setup] screen - [Measure 2]	54
4. [Setup] screen - [Option] tab	55
5. [Setup] screen - [Export] tab	57
a. [Shared folder] - [Setting] screen	58
b. [Network] - [Setting] screen	58
6. [Setup] screen - [Print] tab	59
7. [Setup] screen - [Print/Export] tab	60
VIII. MAINTENANCE	61
1. Storage and handling condition	62
a. Disassembly of the product and transport	62
b. Conveyance	63
c. Replacement of fuse	63
d. Refill of chinrest liner	63
2. Cleaning instructions	64
a. Cleaning of headrest and chinrest	64
b. Cleaning of external cover	64
c. Cleaning of LCD touch panel	64
d. Cleaning of measurement window glass	64
3. Periodical inspection and maintenance	65
4. Confirmation of measurement accuracy	65
IX. ERROR AND TROUBLESHOOTING	66
1. Error display	67
2. Troubleshooting	69
X. TECHNICAL DESCRIPTION	71
1. Technical data	72
a. Product lifespan	72
b. Disposal	72
c. Product weight & dimensions	72
d. Precise performances as intended by Essilor	72
e. Precise performances accuracy / function	74
2. Electromagnetic compatibility	75

3. IT requirements	78
XI. SYMBOL EXPLANATION	79
1. On the document	80
2. On the device	80
3. On the packaging	81
XII. EXCLUSION OF LIABILITY	82
XIII. QR CODE	84
XIV. CONTACT INFORMATION	88

I. INTRODUCTION



 The latest version of this user manual is available on a web space.
To access other available languages, please scan the QR code available at the end of this user manual > QR Code Chapter (p.84).

For a safer, more effective use, follow the instructions outlined in this manual.

Copyright © 2024 Essilor - Original manual - All rights reserved.

Essilor International

147 rue de Paris, 94220, CHARENTON-LE-PONT

www.essilor.com

All reproduction of the content of this document, whether in part or as a whole, for the purpose of its publication or dissemination by any means and in any format whatsoever, even free of charge, is strictly prohibited without Essilor's prior written consent.

II. DIRECTION FOR USE



1. Intended use

a. Intended purpose

AKR800 is intended to objectively measure the refractive power of the eye and to measure the corneal curvature radii.

b. Indications for use

AKR800 is intended for use in cases of ametropia and for routine checks by the eye care professional.

2. Expected clinical benefit

To benefit from a prescription for a compensation solution (refractive power) in agreement with the state-of-the-art vision care.

To benefit from a prescription for a compensation solution (Contact lens curvature) in agreement with the state-of-the-art vision care.

3. Contraindications

No known contraindications for the use of the device.

4. Side effects

There are no known side-effects.

Please report any serious incident that occurred in relation to the device to essilor-instruments-vigilance@essilor.com and to the local competent authority for medical devices.

5. Intended population

Adults and children who may require the application of a visual compensation.



6. Intended users

This device is intended for eye care professionals use only.

III. CAUTIONS AND WARNINGS



1. Definitions

SYMBOL	DESCRIPTION
	Caution: a hazardous situation that, if not avoided, could result in minor or moderate injury.
	Warning: a hazardous situation that, if not avoided, could result in death or serious injury.
	Important and/or useful additional information to learn relating to the text in this manual.



- Do not touch the external connection terminal and a patient at the same time. It can result in electric shock.
- Do not squeeze a patient's finger when moving the chinrest vertically. It can result in patient's injury.
- Do not squeeze a patient's finger in the cases during the operation of this device. It can result in patient's injury.



- Warnings and precautions should be strictly observed.
- It can result in failure, breakage, electric shock, fire and so on. Disconnect the plug immediately and contact your local distributor in case of malfunction (noise, smoke etc.). It can result in fire or injury if you keep using it.
- Connect the power cord with protective earth to the three-core socket with grounding. It can result in fire or electric shock at the time of earth leakage.
- Do not attempt to disassemble the device. It can result in malfunction or fire.
- If liquid is spilled on this device or a foreign substance is entered in it, unplug the power cord and contact your local distributor.



- The safety precautions and operating procedures must be thoroughly understood prior to operation of the device.
- The device complies with ISO 10342 subclause 4:2010 (Ophthalmic instruments - Eye Refractometers) and ISO 10343 subclause 4:2014 (Ophthalmic instruments - Ophthalmometers).
- The dioptic powers are indicated with reference wavelength $\lambda_d = 587.56 \text{ nm}$.



- Do not install the device near a radio equipment of TV or radio. The reception can be disturbed by electrical noise.
- Do not use organic solvents such as thinners which will dissolve the surface of the device. It can result in deterioration, breakage or injury.
- Do not install the device with the power cord inserted. It can result in injury due to its dropping.



- It affects its measurement accuracy if fingerprints or dust etc. are on the optical parts, such as the glass of the view window.
- Do not touch them with hands, and also avoid dust. If fingerprints or dust are adhered on the optical parts, such as the glass or lens etc, wipe it gently with a soft cloth.
- During measurements, observe it closely from the side of the device. The measurement unit could come into contact with a subject's eye or nose.

2. Product safety



Before USE, READ THIS MANUAL.

- The safety precautions and operating procedures must be thoroughly understood prior to operation of the device.
- This manual includes the information about basic operation, inspection and maintenance etc. of AKR 800.
- This device and the contents of this manual comply with IEC60601-1.
- The current version of the product software is V1.

a. Unpacking & Storage



Do not store the product:

- Where dust accumulates.
- Where water may get on the unit.
- Where temperature and humidity are out of the specified ranges.
- Where there is direct contact with sunlight.
- In a unstable and high place.

b. Precautions on IT Network



Ensuring security

Use anti-virus software to protect external devices such as PCs and USB memory devices connected to this product. Also apply security update programs to external devices, and set appropriate user names and passwords that are difficult to guess when logging in.

- This device can output the data to PC etc. through LAN, USB-A, RS-232C interface.
- Please refer to the figure below for the characteristics, configuration, technical specifications, output information and its path when connecting to an IT network.
- When connecting to an IT network, please follow the above precautions "Ensuring security" to prevent computer virus infection and information leakage.
- In case of IT failure, several troubles may occur.

Poor communication between LAN/USB-A/RS 232C makes it impossible to output measurement data and patient information, and results data may be lost.

Due to poor communication with USB-A, wrong patient information may be input by barcode, and as a result, measurement may be performed with wrong patient information.

- Connect this device to an IT network that includes other equipment could result in previously unidentified risks to patients, operator or third parties.
- The responsible organization should identify, analyze, evaluate and control these risks. Subsequent changes to the IT network could introduce new risks and require additional analysis.
- Changes to the IT network include:
 - Changes in the IT network configuration;
 - Connection of additional functions to the IT network;
 - Disconnection the device from the IT network;
 - Update of the device connected to the IT network;
 - Upgrade of the device connected to the IT network.
- Please contact your distributor about the detail of this device.

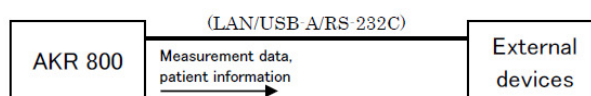

c. Specific considerations regarding electrical safety

Type of protection against electrical shock: Class 1 Equipment (IEC 60601-1).

Class 1 equipment is equipment in which protection against electric shock does not rely on basic insulation only. It also includes an additional safety precaution in that means are provided for the connection of the equipment to a protective earth conductor in the fixed wiring of the installation in which a way with accessible metal parts cannot become live in the event of a failure of the basic insulation.



Degree of protection against electrical shock: Type B Equipment (IEC 60601-1).

Type B equipment provides an adequate degree of protection against electrical shock, particularly regarding allowable leakage currents and reliability of the protective earth connection.

Degree of protection against harmful intrusion of water (IEC 60529): IPX0. This product does not provide protection against intrusion of water.



Classification by safety of use in air/flammable anesthetic gas, oxygen or nitrous oxide/flammable anesthetic gas atmosphere:

- Equipment not suited for use in air/flammable anesthetic gas, oxygen or nitrous oxide/flammable anesthetic gas atmosphere.
- This product should be used in an environment free of flammable anesthetic gas and other flammable gases.

Classification by operation mode: Continuous operation.

d. Patient environment

When the subject or inspector comes into contact with the devices (including the connecting devices) or, when the subject or inspector is in contact with the person that touches the devices (including the connecting devices), the patient environment is shown below.

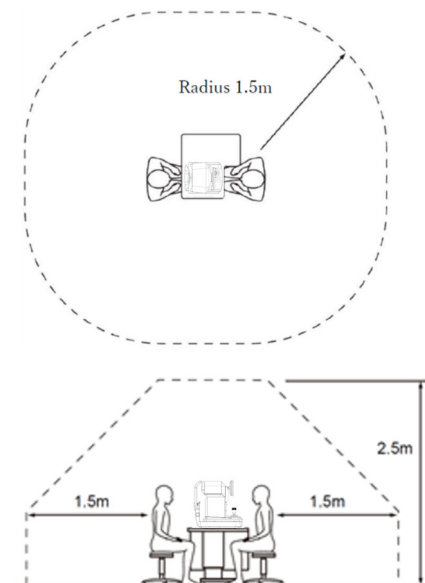

Suitable device to use in the patient environment:

- Personal computer
- Monitor display for PC

Use one that conforms to the safety standards of IEC 60601-1 or IEC 62368-1.



- Don't connect an additional power strip or an extension cord to the system.
- Don't connect any device which is not recognized as one component of the system.



If it can be identified that turning this device On or Off causes harmful interference to other devices, take one of the following actions:

- Reorient or relocate the receiver.
- Increase the separation between devices.
- Connect to a power strip on a different branch circuit.

e. Warning labels on the device

The warning labels are placed on this product for ensuring safety. Follow the indicated description, and use this product properly. If any of the following labels are missing, contact your local distributor or business contact on the back cover of this manual.

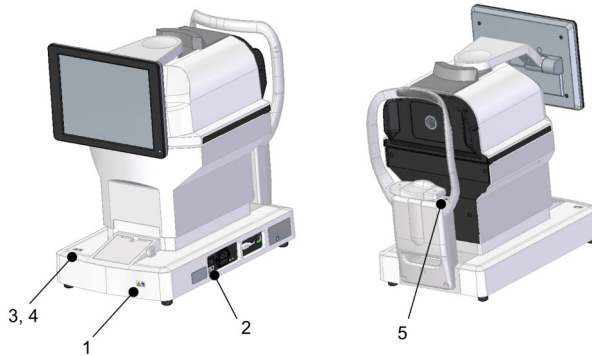

1		Warning It can result in injury due to electric shock.
2		Warning At a time of fuse replacement, disconnect the power cord from the main unit, and replace it with the specified fuse. It can result in injury or fire due to electric shock.
3		Caution At a time of operating the main unit, be careful not to come into contact with a patient's nose. It can result in injury of a patient.
4		Caution At the time of operating the chinrest vertical motion switch, be careful not to catch a patient's finger. It can result in injury of a patient.
5		Degree of protection against electrical shock: Type B Equipment.

IV. PRODUCT DESCRIPTION



1. Product plan with description

a. Main unit

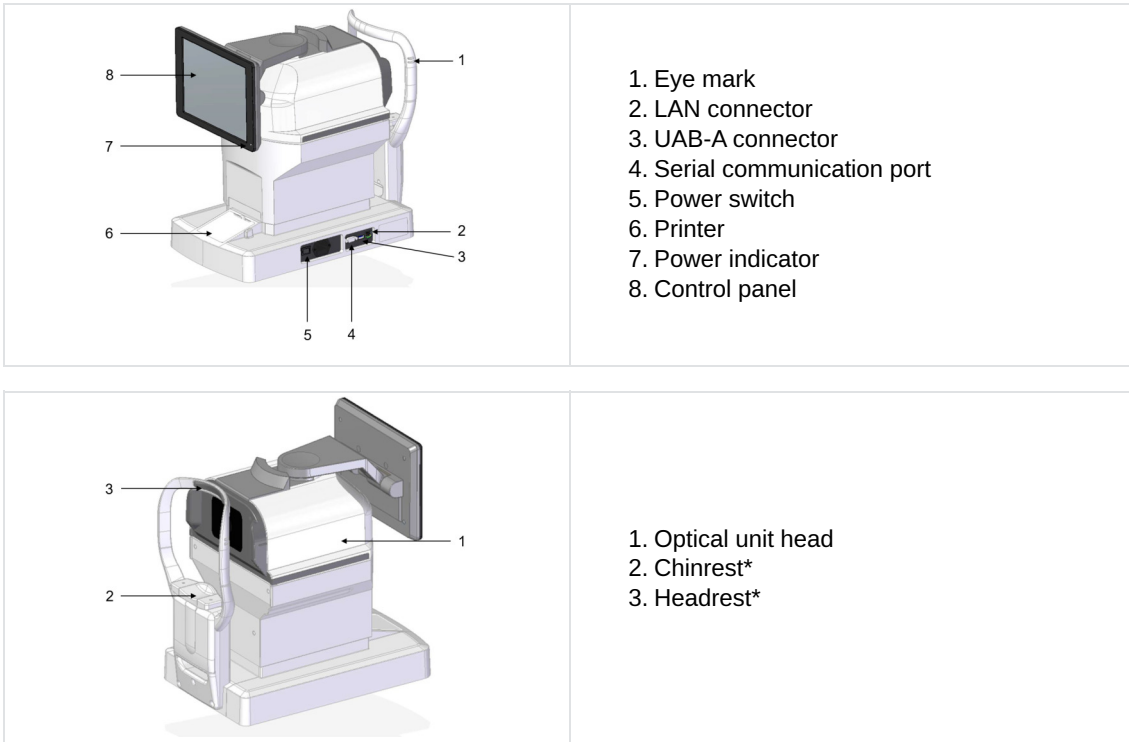

*Applied part



There is the parts list separated from this manual.

b. Operations on control panel

The measurement result and setting conditions, as well as observation image, are displayed.



- Do not use something sharp such as a ballpoint pen to operate the control panel. It can result in breakage of the control panel.
- Do not point more than 1 point at the same time on the control panel.
- Do not press the control panel strongly, otherwise, the measurement unit will moved and you will miss the capture of the image. Operate the touch panel with appropriate handling.

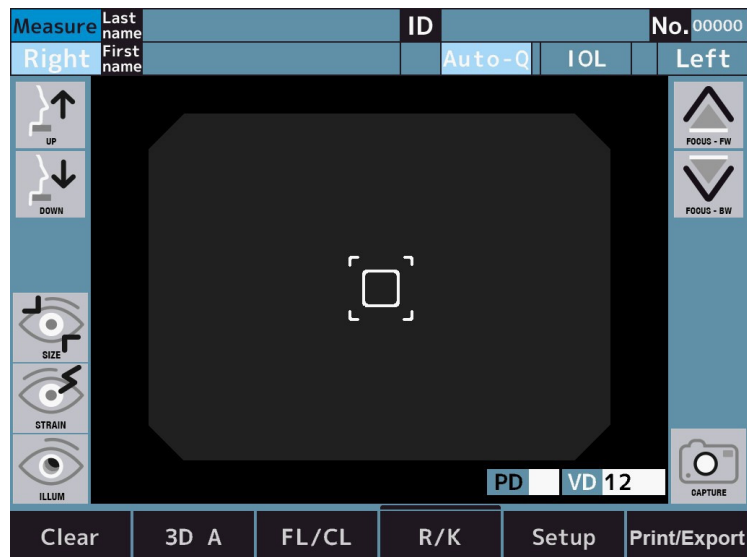

- Tapping ⇒ Used for selection.
Press the screen lightly.
- Holding down ⇒ Used for keep driving.
(Driving of chinrest and optical head)
Hold down the screen lightly.

2. Description of LCD touch panel

a. Measurement mode

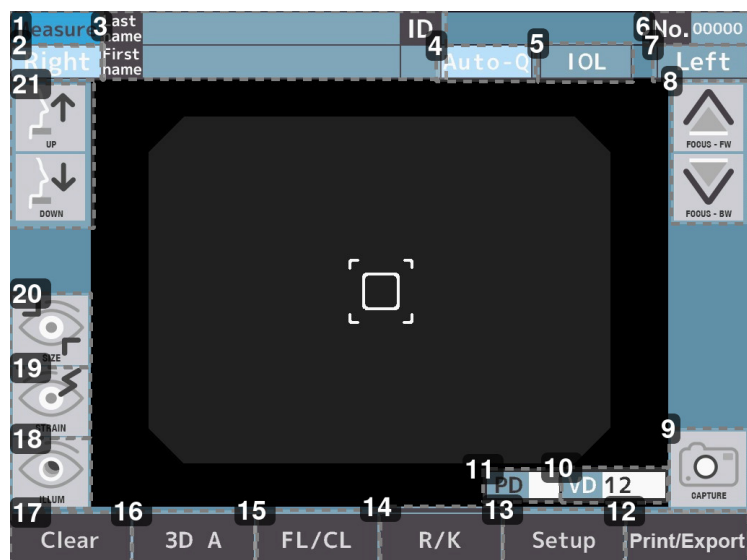

1. Name of screen (measurement mode)

2. R switch

[Right] / [Left]: Select either left or right eye. The optical head moves to the direction of the selected eye by tapping these buttons. The [Right] and [Left] buttons are in light blue while they are selected.

3. Patient information input switch

[Last name] / [First name] / [ID]: Input the last name (up to 32 letters), first name (up to 32 letters) and patient ID (up to 13 letters).

- 4. Measurement start method switch**
 [Auto-Q] / [Auto] / [Manual]: Select the measurement start method.
- 5. [IOL] switch**
 Select the [IOL] measurement mode.
- 6. No. Switch**
 The No. is displayed.
- 7. L switch**
 [Right] / [Left]: Select either left or right eye. The optical head moves to the direction of the selected eye by tapping these buttons. The [Right] and [Left] buttons are in light blue while they are selected.
- 8. Optical head back-and-forth motion switch**
 The optical head moves back and forth to a subject's eye.
- 9. Measurement switch**
 Measurement will be started.
- 10. [VD] switch**
 Select the vertex distance.
 *FL mode only. It can be switched between 0, 10, 12, 13.5 and 15mm.
- 11. [PD] switch**
 Pupil distance indication*.
- 12. [Print/Export] switch**
 The displayed measurement result is output.
- 13. [Setup] switch**
 Switch to the setup screen.
- 14. Measurement mode switch**
 Select the measurement mode. It is:
 1. [R/K]: Refractive & keratometry continuous measurement
 2. [REF]: Refractive measurement
 3. [KRT]: Keratometry measurement
 4. [P.K]: Peripheral kerato measurement
 5. [R-SMP]: R-SMP measurement
- 15. Cornea top distance switch**
 Switch the corneal [Vertex] distance (frame value/ contact value).
- 16. Alignment mode switch**
 [3D A] / [3D M]: Switch the auto-alignment operation.
- 17. [Clear] switch**
 All of the measurement values are cleared.
- 18. Retro illumination mode transition switch (optional feature, only available on the AKR800NV commercial offer)**
 Select the Retro Illumination mode.
- 19. Accommodation measurement mode transition switch (optional feature, only available on the AKR800NV commercial offer)**
 Select the Accommodation mode.
- 20. Corneal diameter measurement mode transition switch**
 Select the [WTW] mode.
- 21. Chinrest vertical motion switch**
 The chinrest moves up and down.

* The value displayed is informative.

The practitioner is recommended to get more accurate information by using a device intended by its manufacturer to directly measure these parameters.

b. Measurement mode - P.K



1. *P.K. measurement method switch*
[P.K. A] / [P.K. M]: Select the measurement method.
2. *Target selecting switch*
Select P.K target. Display current measurement area.
3. *Measurement switch*
Measurement will be started.

c. Measurement mode - R-SMP

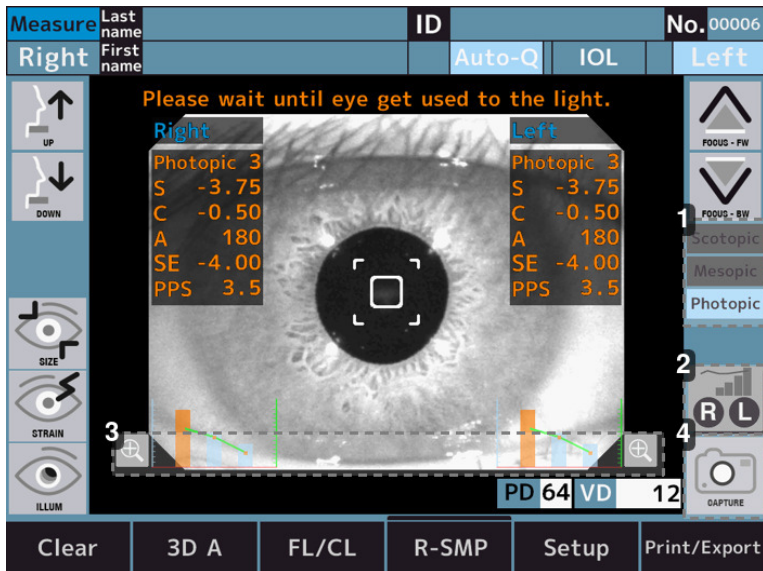

1. *Target light status display*
[Scotopic] / [Mesopic] / [Photopic]: Displays the status of the target light.
2. *Graph switch*
 - : Enlarge the graph of right eye data.
 - : Enlarge the graph of left eye data.
 - : Enlarge the graph of the currently selected eye data.

3. Magnification switch

Enlarge the graph of right eye (right side of the screen) and left eye (left side of the screen) data.

4. Measurement switch

Measurement will be started.

d. Measurement mode - WTW

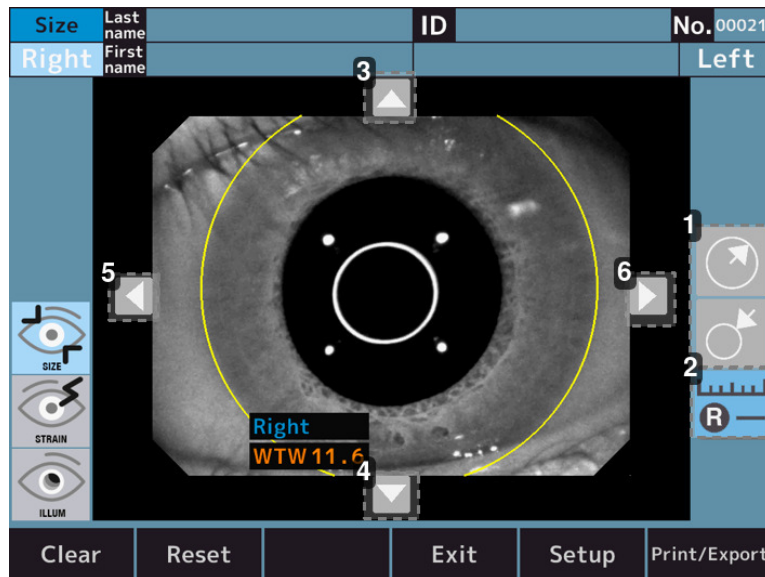

1. Circle size adjustment switch



Enlarges the size of the circle that serves as a reference for measuring the diameter of the cornea.



Reduces the size of the circle that serves as the standard for measuring the diameter of the cornea.

2. Measurement switch



Switch to measurement mode of right eye corneal diameter.



Switch to measurement mode of left eye corneal diameter.



Switch to measurement mode of the currently selected eye corneal diameter.

3. Circle position adjustment switch - Up

Move up the position of the reference circle to measure the diameter of the cornea.

4. Circle position adjustment switch - Down

Move down the position of the reference circle to measure the diameter of the cornea.

5. Circle position adjustment switch - Left

Move the position of the reference circle to the left to measure the diameter of the cornea.

6. Circle position adjustment switch - Right

Move the position of the reference circle to the right to measure the diameter of the cornea.

e. Measurement mode - Accommodation (optional feature, only available on the AKR800NV commercial offer)



1. Alignment switch

Realign. : Re-alignment before moving the target.

Realign. : It does not perform re-alignment.

2. Number of measurements switch

Meas. : It is possible to set the number of measurements to 3 times.

Meas. : It is possible to set the number of measurements to 5 times.

3. Error switch

Error check : If measurement error occurs 3 or 5 times, it stops halfway. And when touch the measurement start switch after re-alignment, it starts from target position where error occurred.

Error check : If measurement error occurs 3 or 5 times, it moves to the next target position.

4. Graph switch

R : Enlarge the graph of right eye data.

L : Enlarge the graph of left eye data.

R L : Enlarge the graph of the currently selected eye data.

5. Measurement switch

Measurement will be started.

6. Graph switch

Enlarge the graph of right eye (right side of the screen) and left eye (left side of the screen) data.

f. Measurement mode - Retro Illumination (optional feature, only available on the AKR800NV commercial offer)

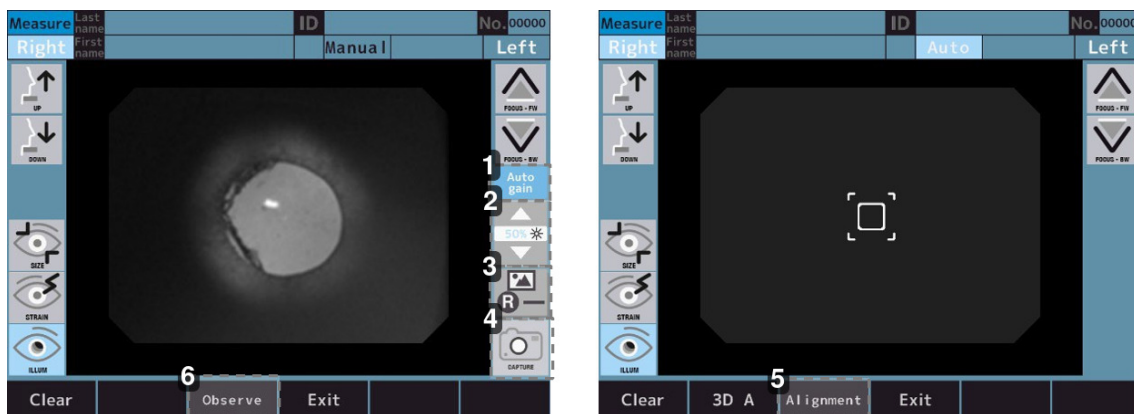

1. Auto gain On/Off switch

 : Perform the auto gain.

 : It does not perform the auto gain.

2. LED light quantity adjustment switch

It is possible to adjust the brightness of the image.

3. Image icon

 : Enter the right eye capture image observe screen.

 : Enter the left eye capture image observe screen.

 : Enter the currently selected eye capture image observe screen.

4. Measurement switch

Measurement will be started.

5. Mode selector switch

Mode to perform alignment.

6. Mode retro-image switch

Mode to observe retro-image.

3. List of accessories

The device has no accessories. However, the following items are supplied with the device:

- Model Eye: (x1)
 - With a contact lens holder. Diopter value is indicated on the sticker
- Power cord: (x1)
 - Name model: KP4819YKS31A or equivalent
 - Length: 2.5m
- Printer paper: (x3)
 - Width: 57mm
 - 2 included and 1 installed in the unit
- Fuse: (x2)
 - T2A L 250V
- Chinrest liner: (x1)
 - 1,000 sheets
- Chinrest liner pin: (x2)
- Dust cover: (x1)

- Operation manual: (x1)

While unpacking, check that these standard items are included.



Extra care should be taken for storage of a model eye. Avoid where the lens of the model eye may be damaged as well as any dusty or humid/steamy environments.

Store the printer papers in a site without direct sunlight, high temperature and high humidity where because they are thermal paper.



- Use only the items specified by us.
Please purchase these items from the distributors as necessary.
- Use of the item (power cord) other than specified below may adversely affect other instruments and/or cause malfunction of this device.

V. OPERATING INFORMATION

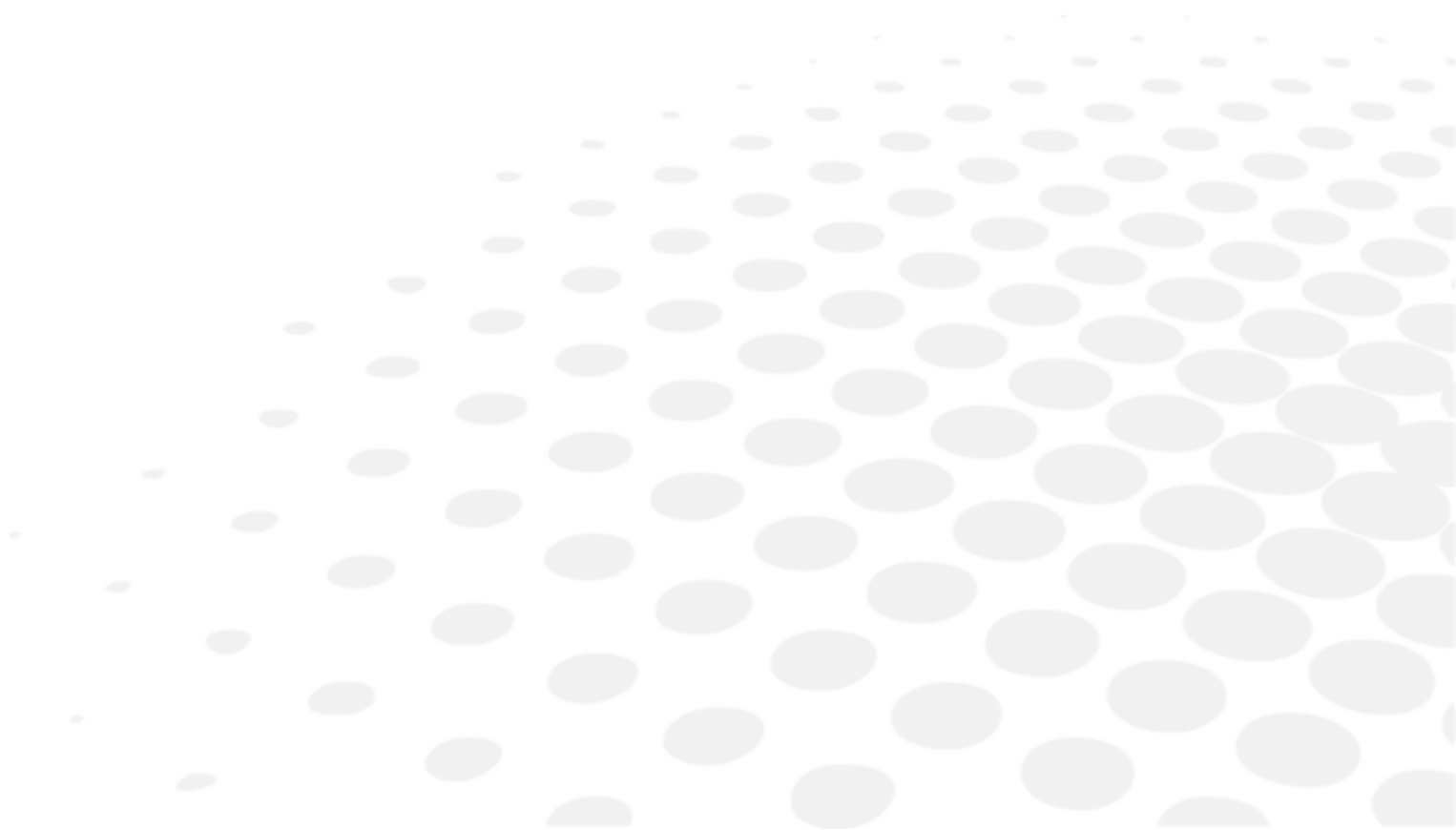

1. Installation of the device



Once installed and placed into service, this device is not intended to be moved from one installation place to another.



- Do not install the device near a radio equipment of TV or radio. The reception can be disturbed by electrical noise.
- Do not install the device with the power cord inserted. It can result in injury due to its dropping.
- Do not install in a unstable place such as an incline. Otherwise, you may drop down the device and get injured.
- When installed on the optical bench, be careful not to grab a finger of examinee. You may get injured.
- Conduct the installation with the power cord unplugged . Otherwise, you may drop down the device and get injured.
- Keep it away from the place where chemicals are stored, or gas generates.
- Keep it away from the sites which may experience strong vibrations or sudden shocks.



- Do not operate it in a place where it is either dusty or grubby.
- Environment with extreme heat and/or humidity should also be avoided. In case of using the device, fulfill the environmental conditions at the time of unpacking and use.

a. Unpacking method of internal packing box

- 1 Cut the fixing bands and pull up the internal packing box.
- 2 Remove the cardboard on the top and included items, then remove the packing material.
- 3 Hold A and B on the base and take out the device.
- 4 Do not hold the head unit, the headrest, the joystick or the LCD unit.
- 5 Remove the buffers after taking it out.

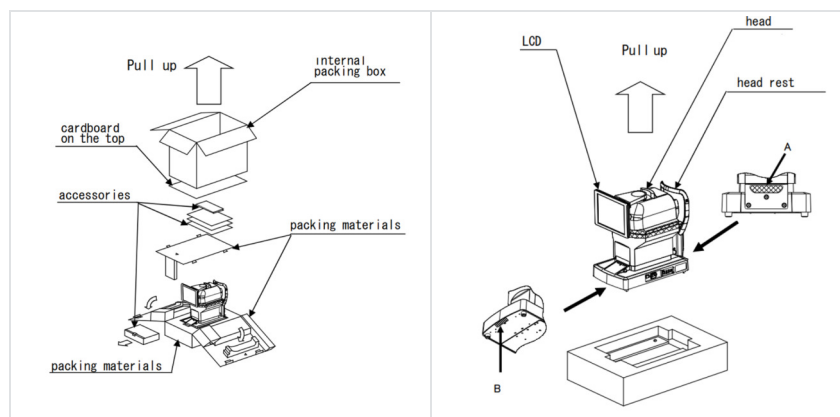

b. Connection of power cord

- 1 Confirm that the power switch of the main unit is Off.
- 2 Attach the power cord to the power inlet.
- 3 Connect the power cord with protective earth to the three-core socket with grounding.



- Do not use power strip or extension cord.
- To avoid fire or electric shock at the time of electric leakage, connect the power cord with protective earth to the three-core socket with grounding.
- Do not touch the power plug with wet hands. It can result in electrical shock.
- Use this device with correct source voltage. If the source voltage is not correct, it can result in malfunction or fire.
- If the power cord is broken (cut, damage on coating, etc.), replace it with the new one. Follow all the precautions.
- Keep the power cord clean from dust, oil, etc. If the terminal unit is not clean, it can result in malfunction or fire.
- If the power cord gets hot when using the device, check if the terminal unit is clean. If it is clean, replace it with the new one. If you keep using it, it can result in fire or injury.
- Hold the plug unit when plugging the power cord in and out. If handling the cord roughly, it can result in breakage.
- Plug out the power cord when the device is not used for a long time.

c. Connection of external input/output terminal



- Do not touch the external connection terminal and an examinee at the same time. It can result in electric shock.
- The instruments which are connected to this device should comply with the safety standard of IEC60601-1 or IEC 62368-1. Also, the instruments should be grounded, or a separator should be used for connection.



Use the shielded wire for the connection cable to protect the output data from noise.

Data output

This device can be connected to the PC or refractor and so on through RS-232C or LAN. The data can be output to the USB memory through USB-A.

- 1 Connect the connecting cord to the external input/output terminal of the device.

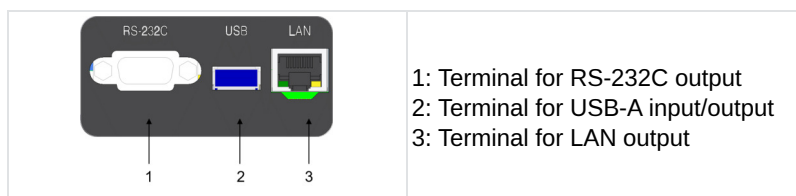

- 2 Connect the other end of the connecting cord to the PC and so on.

Wiring diagram: RS-232C

PC Side Female	Straight Cable	Device Side Male
1 CD	—	1 CD
2 RxD	—	2 TxD
3 TxD	—	3 RxD
4 DTR	—	4 DSR
5 GND	—	5 GND
6 DSR	—	6 DTR
7 RTS	—	7 CTS
8 CTS	—	8 RTS
9 RI	—	9 RI

Note 1: Pin2, 3, 5 are must required

Note 2: Pin7, 8 are option for flow control

Data input

This device can be connected to the barcode reader and keyboard through USB-A.

In order to prevent deterioration of the USB-A connector, it is recommended to connect a USB hub to the USB-A connector beforehand when connecting USB devices.

- 1 Connect the connecting cord to the USB-A input/output terminal of this device.
- 2 Connect the other end of the connecting cord to the external device etc.



- o Connect the USB device to this device with its power Off. It might not be able to recognize the USB device correctly if this device is in operation.
- o Contact your local distributor about connection.

d. Setting of printer paper



- Do not open the printer cover when the printer is in operation. It can result in injury.
- If something is wrong with the printer such as paper jam, solve the problem after turning off the power. It can result in injury.
- Do not touch the printer unit when it is in operation or paper replacement. It can result in injury with a metal part.
- Use the printer paper specified by us. If using the paper other than the one specified by us, it can result in malfunction of the printer.



The paper has 2 sides. If the paper is set in opposite, the data is not printed out.

- 1 Open the cover by pressing the printer cover open switch.

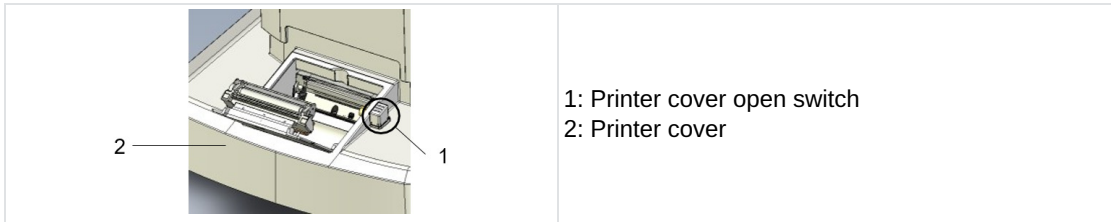

- 2 Set the printer paper roll in place paying attention to the direction of the paper.

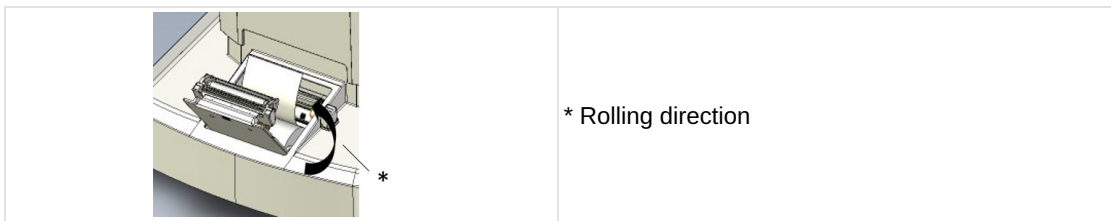

- 3 Set the paper as coming out toward the front.
- 4 Close the printer cover until it clicks.
> If the cover is not closed completely, the error message appears, and cannot print out.

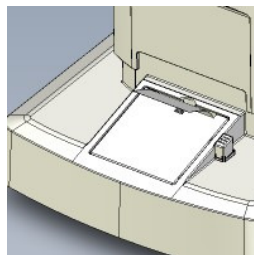

e. Return from sleep mode

If any operations are not performed during the set time while the power is On, the sleep mode is activated.

- 1 Tap the LCD touch panel.
 - > It returns from the sleep mode, and the device can be operated



The time to activate the sleep mode can be changed on [Save(min)] of [Option] in the setup.

2. Turning On/Off the device

a. Turning ON

- 1 Insert the plug of the power cord in the three-core socket with grounding.



If applicable, connect the external connection equipment, and turn it On.

- 2 Turn On the main unit.
 - > The logo screen and measurement screen are displayed.



Brightness adjustment of LCD touch panel

- o The brightness of this device is adjusted accurately before shipment.
- o If necessary, adjust the brightness in [Brightness] of [Option] in the [Setup] screen.

b. Turning OFF

- 1 Turn Off the power.



If applicable, turn Off the external connection equipment.

- 2 Disconnect the plug of the power cord from the three-core socket with grounding.

3. Connection to other instruments

Please refer to section 1 of chapter V for detailed information.

VI. USE OF THE DEVICE

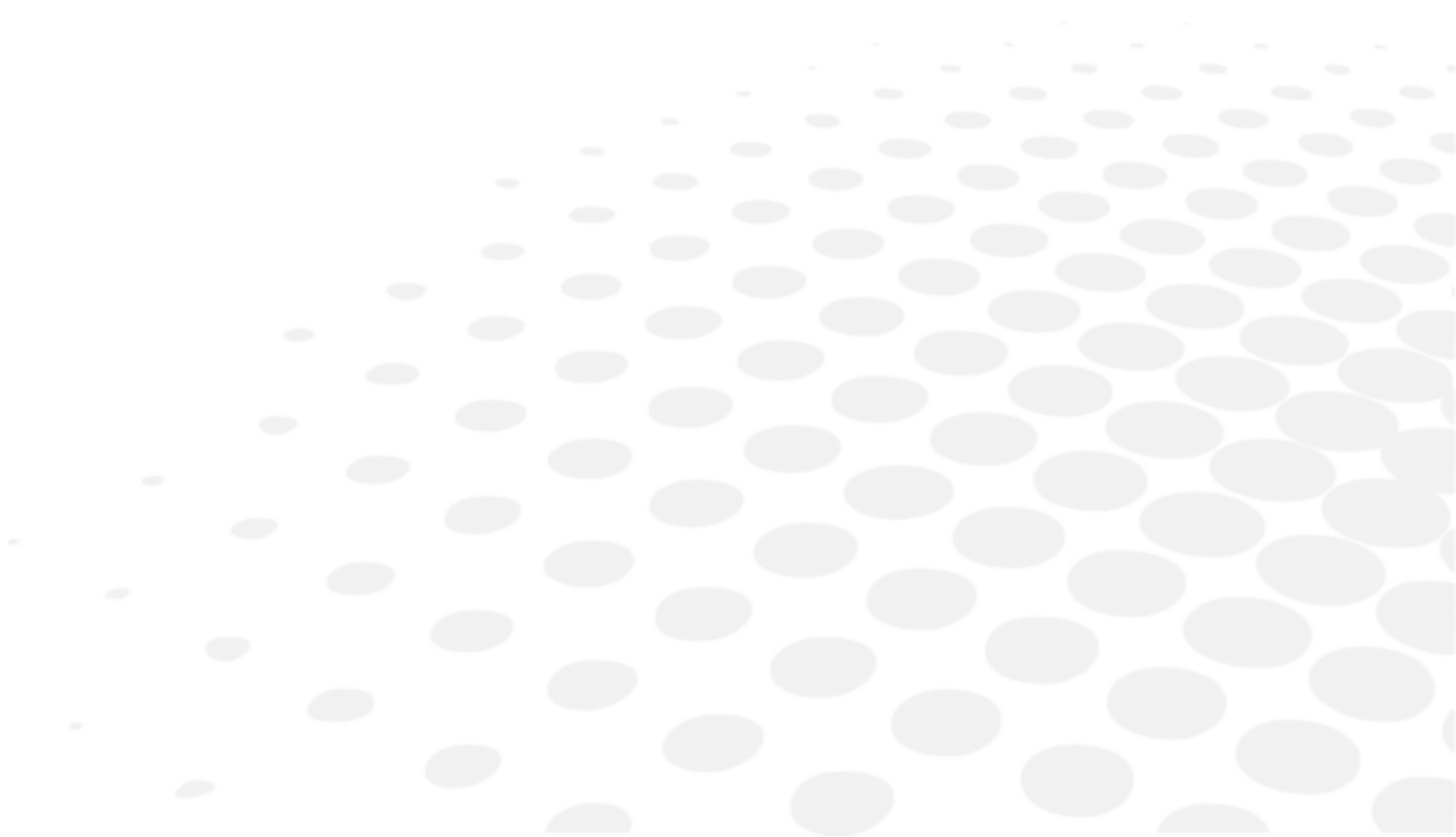



If fingerprints or dust etc. are on the optical parts, such as the glass of the view window, it will affect the measurement accuracy. Do not touch them with hands, and also avoid dust. If fingerprints or dust are adhered on the optical parts, such as the glass or lens etc, wipe it gently with a soft cloth.

During measurements, observe it closely from the side of the device. The measurement unit could come into contact with a subject's eye or nose.

1. Flow operation

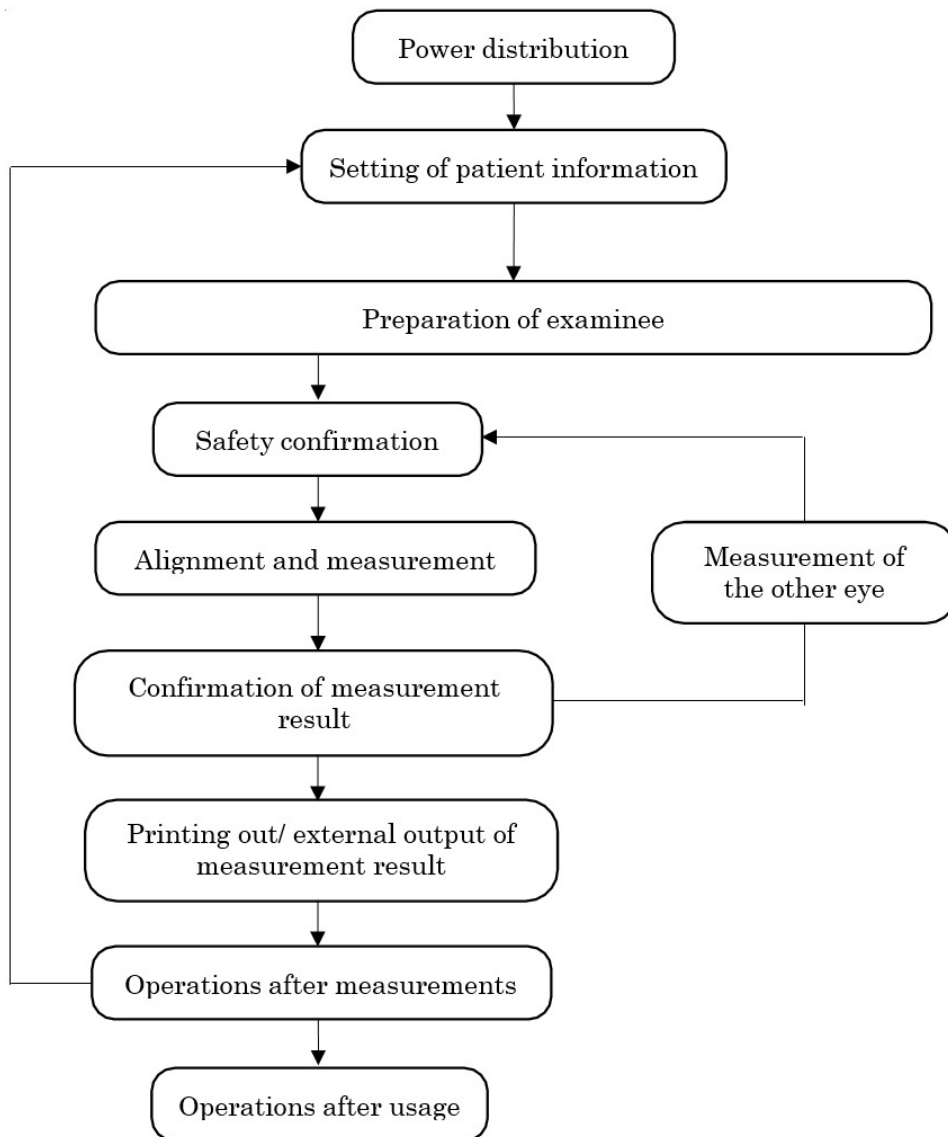

2. Setting of patient information

- 1 Tap the patient information input switch.

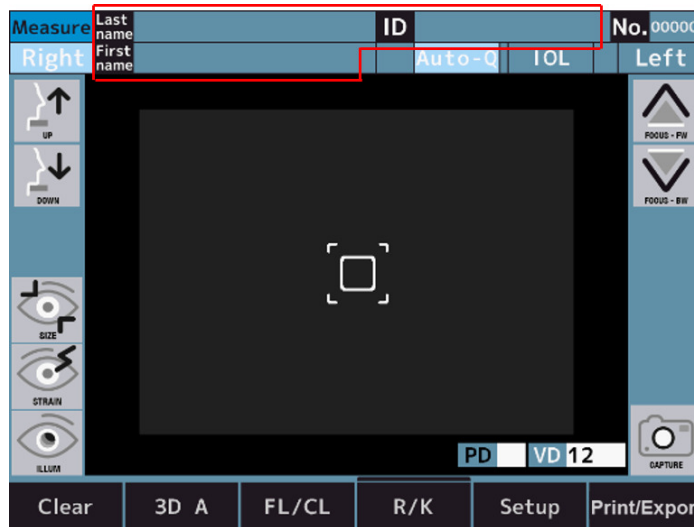

- 2 The screen is switched to the one inputting the patient information input screen by pressing the input buttons.



1. Patient ID input section
2. [Last name] input section
3. [First name] input section
4. Input buttons
5. [Shift] switch
6. [Clear] switch
7. [Exit] switch
8. [Cancel] switch

- 3 Return to the measurement screen after inputting the patient information by pressing the [Exit] button.
- 4 Confirm that the patient information is updated.



It can switch between the capital and small letters by tapping the shift switch.

3. Preparation of examinee



- Adjust the height of the optical bench and chair so that the patient feels comfortable during measurements. It can result in making the patient feel stressed, or incorrect measurement values.
- Use this device with great caution because part of this device might come into contact with a subject's eye or nose during its operation.
- If No. is not registered, the device will number it automatically in order of exam. The display of the measurement and analysis result in the external output can be set to Off.



For sanitary reasons, dispose the top chinrest liner after every patient.

- 1 Check the measurement screen.
- 2 Dispose one chinrest liner to make the chinrest clean.



Feed the chinrest liners if it is short.

- 3 Wipe the headrest.



If the headrest or chinrest gets dirty, wipe it with neutral detergent.

For sanitary reasons, disinfect the applied parts such as headrest and chinrest with ethanol.

> Ethanol for disinfection contains 76.9 to 81.4vol% of ethanol (C₂H₆O) at 15°C (specific gravity).

- 4 Ask the patient to sit down in front of the device.
- 5 Adjust the optical bench and chair so that the patient can place his/her chin in a comfortable position.
- 6 Adjust the height of the chinrest by holding down the chinrest vertical motion switch so that the height of the eye mark on the chinrest and a subject's eye are aligned.

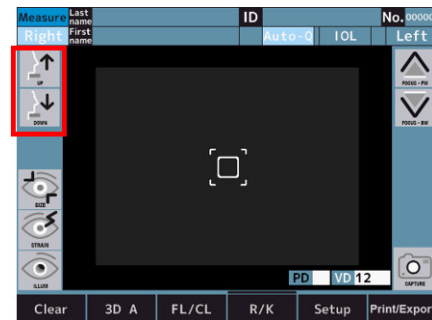
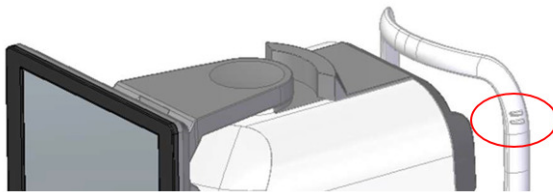

- 7 Ask the patient to place his/her forehead on the headrest.



If the patient moves his/her head, the measurement values are adversely affected.

4. Alignment and Measurement

 During measurements, carefully check from the side of the device so that the measurement unit and subject's eye do not come into contact.

The measurement unit might come into contact with a subject's eye and the cover might come into contact with a patient's nose.

- 
- If subject's eyelid or eyelashes covers his/her pupil, the measurement in auto mode might not be performed. In these cases, ask him/her to open his/her eye wider or to pull up his/her eyelid with his/her hand.
 - The auto mode might not work for a patient with frequent blinking or with abnormality on the corneal surface due to a corneal disease and others. In this case, take measurements in manual mode.
 - The auto alignment function might not work for a patient with glittering eye makeup on her eyelid or its peripheral. In this case, take measurements in manual mode.
 - Operate this device with great care because part of this device might come into contact with a subject's eye or nose.
 - If tapping the area other than the one around the pupil, alignment cannot be performed normally, and a part of the device might come into contact with a patient's nose.
 - Fluctuation of the measurement values may occur if the examinee looks at something other than the target. Urge the examinee to concentrate on the target set in front.

1 Check the measurement screen.

-  If the indication of the 3D Auto/Manual switch is [3D A], it means you are in auto mode.
If the indication is [3D M], switch it to the auto mode by tapping it.

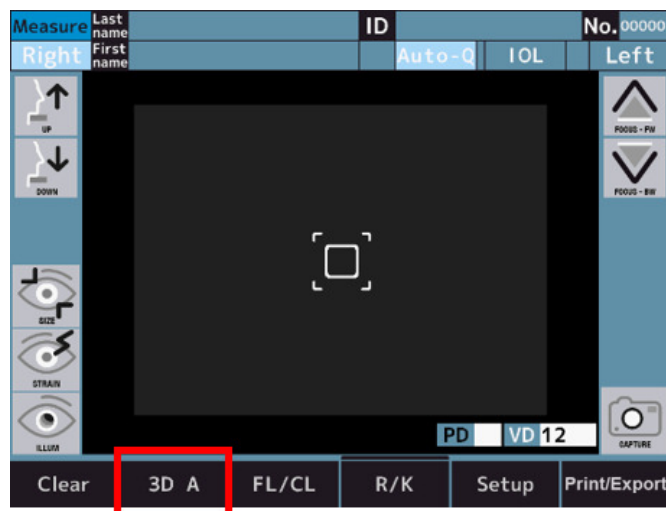

2 Alignment can be performed on the LCD touch panel.

Before performing alignment, it is necessary to calibrate the center position of the pupil and focus position manually.

- 3 Perform alignment so that the center of the pupil is placed in the reticle by pressing down the screen.

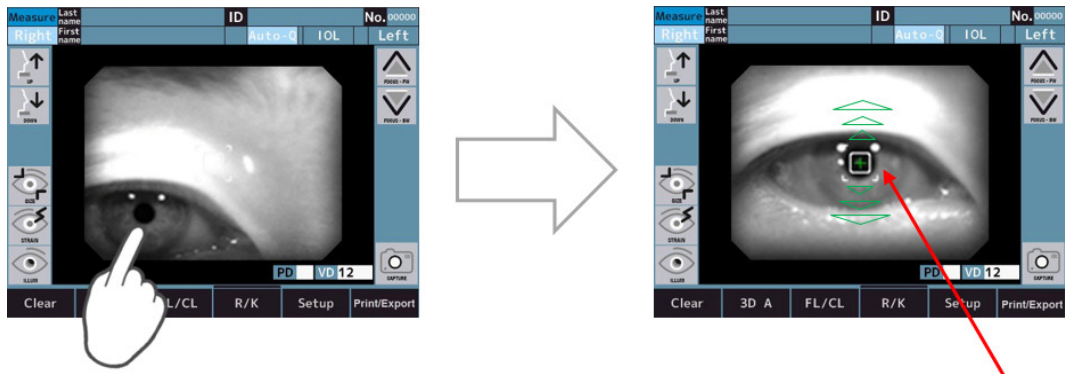

> The alignment is started by tapping the screen.



- In the case of measurement start method switch is Auto or Auto-Q, measurement is started automatically after the alignment.
- In the case of measurement start method switch is manual, measurement is started by touching measurement switch after the alignment.



When the optical head is moved to the traveling limit vertically, horizontally and in depth, the yellow limit lines are displayed on the screen. Move the optical head to the position that alignment can be performed. If the pupil center of an examinee cannot be performed in the vertical and horizontal movable range, adjust height of the chinrest after checking the eye mark position or ask an examinee to move his/her face to a movable direction.

Vertical and horizontal directions	Examinee's direction	Operator's direction



The error message is displayed on the top of the screen when auto alignment is failed.



*Assist facility mode only

1. [Display the eye to align it.]
The eye is not visible on the monitor.
Manually move the optical head to the position where the eye can be seen.
2. [Focus signal cannot be detected.]
The eye is not in focus.
Use the "Optical head back-and-forth motion switch" to focus on the eye.
3. [Perform alignment manually.]
Auto-alignment is not working properly.
Please switch the "3D Auto/Manual switch" to "3D M" and perform manual alignment.



When measuring an [IOL] (intraocular lens) implanted eye, an eye with a cataract, or an eye with scratches on the cornea, the measurement errors may occur, and it is difficult to complete the measurement with [REF] measurement.

In this case, it is easier to measure if moving the device closer to the examinee. Also, these can be measured with [IOL] mode.

5. Confirmation of measurement result



1. Number of refractive measurement
2. Refractive measurement value
 - o [S]: Spherical value
 - o [C]: Cylindrical value
 - o [A]: Axis angle
3. Number of kerato measurement
4. Kerato measurement result
 - o [R1]: Radius of curvature (Max.)
 - o [R2]: Radius of curvature (Min.)
 - o [AX]: Axis Angle
5. Pupil diameter estimation result*
[M] is the setting for [Target] on the [Setup] screen when estimating pupil diameter.
 - o [B]: Bright
 - o [M]: Middle
 - o [D]: Dark

6. *[Vertex] distance*

7. *Pupillary distance**

Far vision

8. *Pupillary distance*

[NPD]: Near vision

*The value displayed is informative.

The practitioner is recommended to get more accurate information by using a device intended by its manufacturer to directly measure these parameters.



- The [PD] value is indicated after the refractive power of both right and left eyes are measured. The order of the eye to be measured is not important.
- The [NPD] value is indicated only if the number of [W-D] on the [Setup] screen is set.
- The [PS] value is indicated only if the setting of [Pupil Size] on the [Setup] screen is set.

6. Print out and external output of measurement result



Because the printer paper is a thermal paper, it cannot be stored for a long time. Please copy the record on a different paper and store it.

This device can print out the measurement values from the printer.

Normally you can print the measurement result out after measurement. For refractive measurement, a maximum of ten data for each eye can be saved and the most reliable value among them is indicated as optimum value. The optimum value is printed out only when more than three times of measurement is made for each eye. The format of the output [All], [Eco] or [Off] can be set on [Print REF] and [Print KRT] on the [Setup] screen.

- [All]: Print out a maximum of ten datas of the refractive measurement or Kerato measurement for each eye.
- [Eco]: Print out only the optimum values for all of the measurement.
- [Off]: Print out no data



- If the red line appears at the end of the printer paper, replace the paper soon.
- When [Error Printer cover opened.] is displayed, close the printer cover tightly.
- The measurement values are output to the data store site set in [Terminal] if [XML and [Standard] and [Report] on the [Export] tab in the setup is set as other than [Off].

7. Measurement of the other eye



- If [R/L Auto] is set to On, the optical head automatically moves to the position measuring the opposite eye.
- If [R/L Auto] is set to Off, move the optical head to the position measuring the left eye by tapping the Left switch.

1 Take measurements.

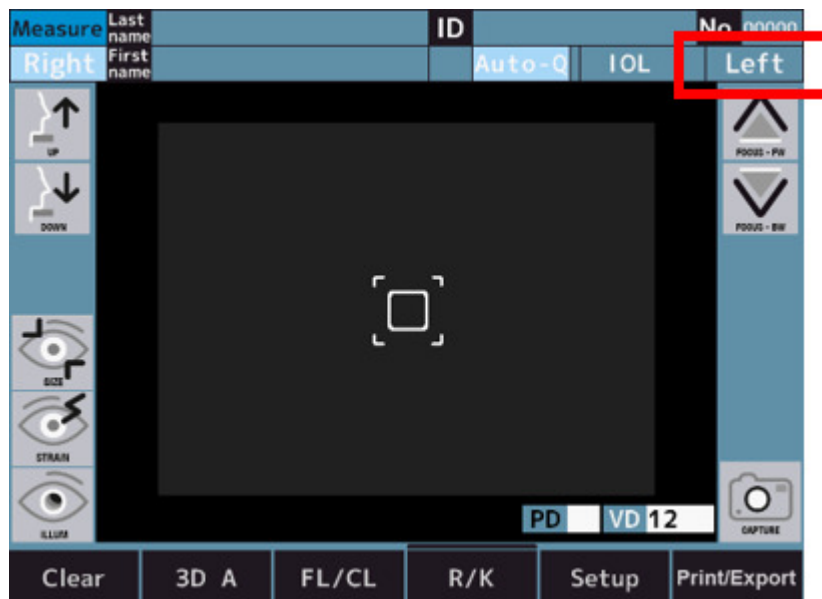

2 Perform measurements, then print out the measurement and analysis result as well as the external output after finishing the measurements.



- If [R/L Auto] on [Measure 2] in the [Setup] screen are set as On, the optical head moves to the other side automatically, and a measurement is started.
The eye to be measured cannot be switched correctly if a patient closes his/her eye or blinks during switching.
- If [R/L Auto] is set to Off, press [R] or [L] switch on the opposite side.



Do not move the optical head to the other eye by tapping or holding down the screen. The device might come into contact with a patient's nose.

8. Measurement and analysis result

a. Printer output content

The measurement and analysis result can be printed out by pressing the output switch on the measure/analysis screen.

When print [REF/KRT] is set to [All/Eco]:

Sample of Printout

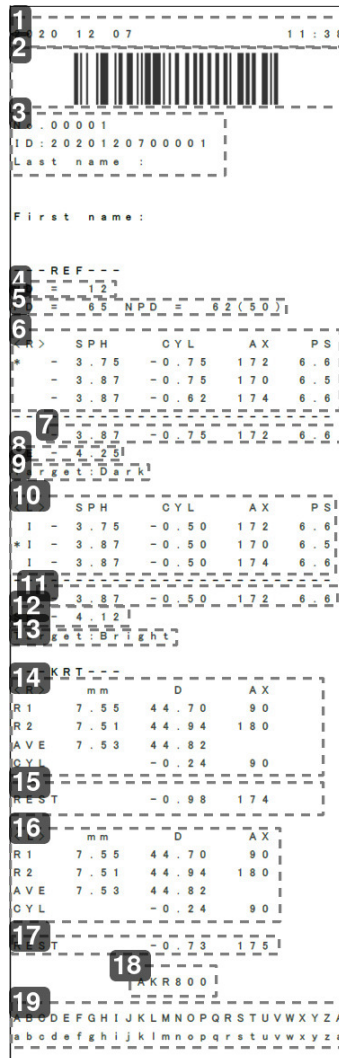

1. Date and time

2. Patient ID barcode

3. Patient information

- o No.
- o Patient ID
- o Examinee's name

4. [Vertex] distance

5. Pupil distance/PD for near vision

*

6. Refractive data - Right

7. Optimum value - Right

Indicated when each eye is measured more than three times.

8. Spherical equivalent - Right

9. Target value - Right

This is the setting value for [Target] on the [Setup] screen when estimating the pupil diameter.*

10. Refractive data - Left

11. Optimum value - Left

12. Spherical equivalent - Left

13. Target value - Left

14. Keratometry data - Right

15. Residual astigmatism - Right

16. Keratometry data - Left

17. Residual astigmatism - Left

18. Product name

19. Message area

* The value displayed is informative. The practitioner is recommended to get more accurate information by using a device intended by its manufacturer to directly measure these parameters.

b. Description of report output

The measurement result can be output to the USB memory or PC in the format of the report by pressing the output switch on the measure/analysis screen if each setting is set on the [Export] tab of the [Setup] screen.

In the format of the report, the corneal size, retroillumination image, accommodation value, and [R-SMP] measurement are output.

Sample of report

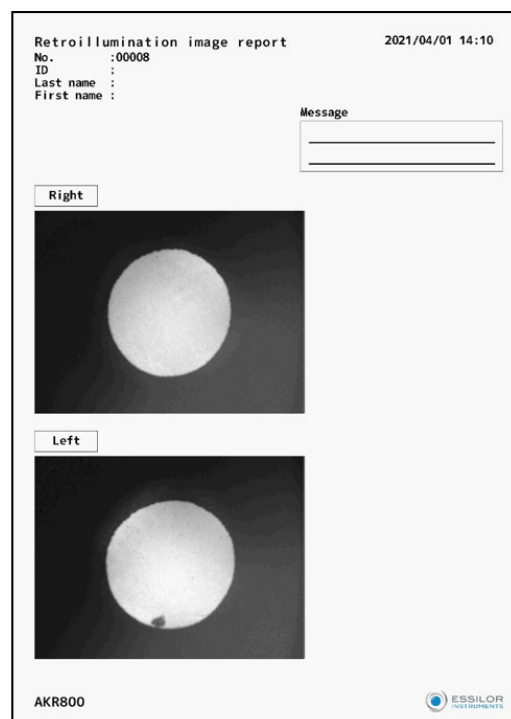
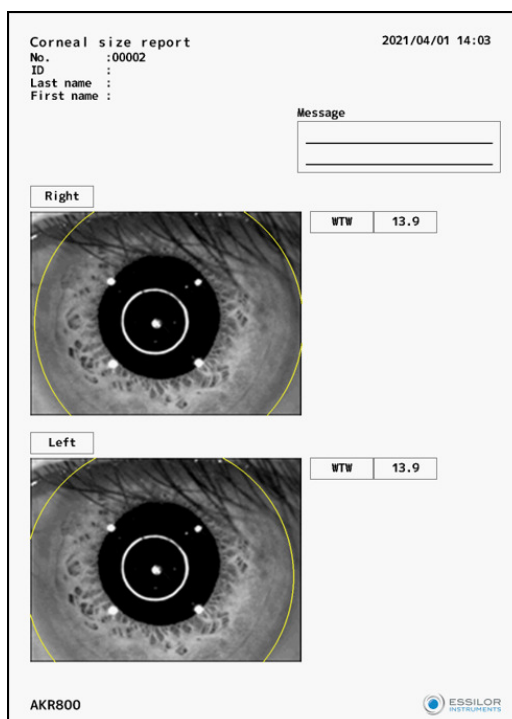

9. Operation after measurement

- 1 Tell the patient that the measurements are finished.
- 2 Tap the [Clear] switch.
 - > All of the measurement values are deleted.

10. Optional function measurement method

a. [P.K.]

- 1 Switch to the [P.K.] measurement mode screen.

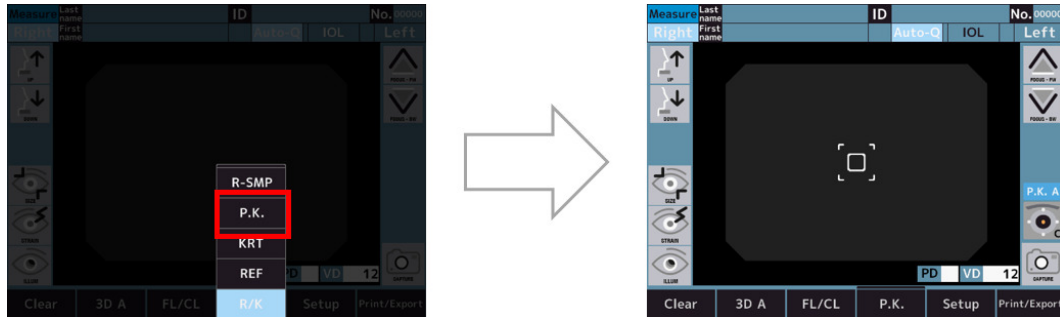

- 2 Perform the measurement.

The usual measurement is taken in order of H → V → S → T → I → N.

- [H]: Horizontal measurement
- [V]: Vertical measurement
- [S]: Superior measurement
- [T]: Ear side measurement
- [I]: Inferior measurement
- [N]: Nose side measurement.
- When the measurement method is Auto [P.K. A]: Once alignment is performed and measurement is started, all directions are automatically measured.
- When the measurement method is Manual [P.K. M]: Center [H/V] measurement is performed after alignment.

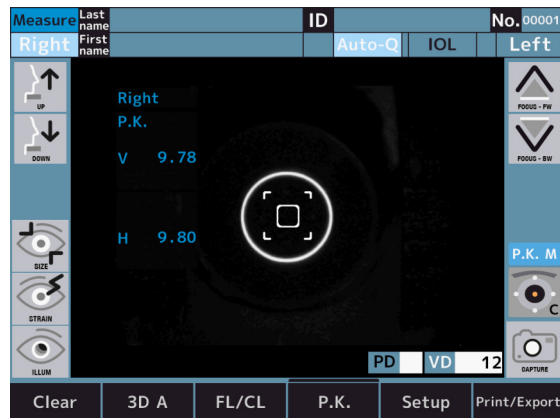



If you touch "Target selecting switch" without measuring the center, the following error message will be displayed.

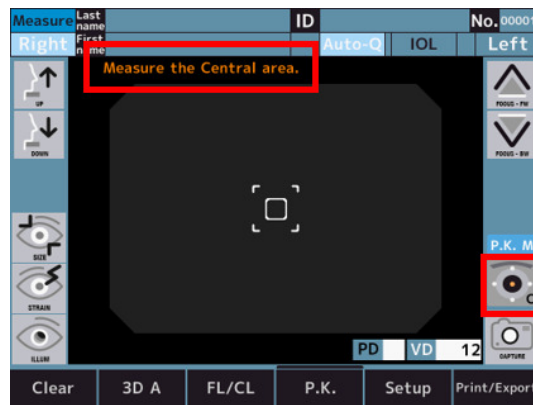

3 After measuring the center [H/V], touch "Target selecting switch" to switch to [S].

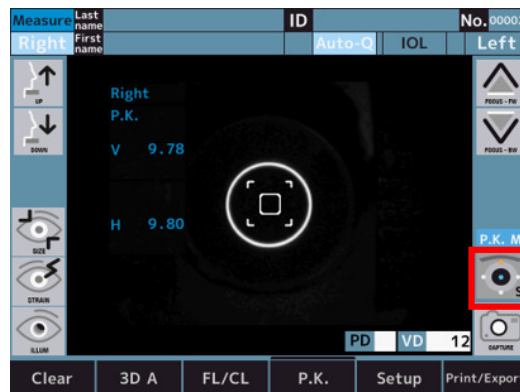

4 Superior (S) measurement is performed after alignment.

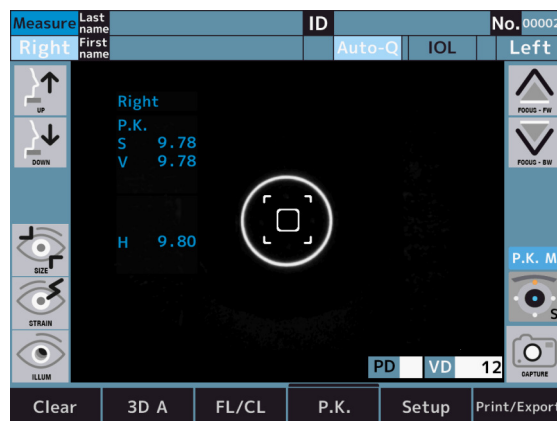

- 5 Measure the other peripheral kerato in turn.

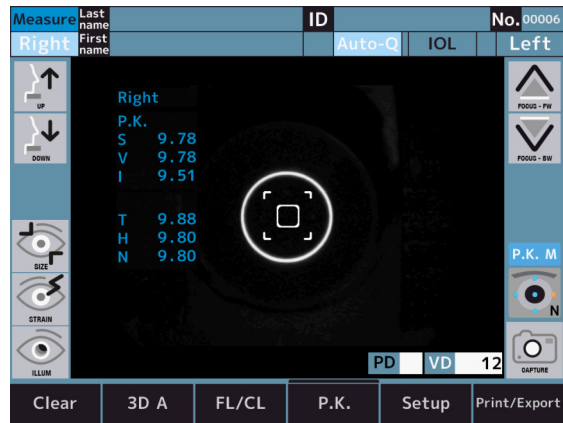

The color of the icon changes depending on the measurement status.

Icon	Description
	Not measured
	Measurement success
	Measurement failure

Example of measurement failure



b. [R-SMP]

- 1 Switch to the [R-SMP] measurement mode screen.

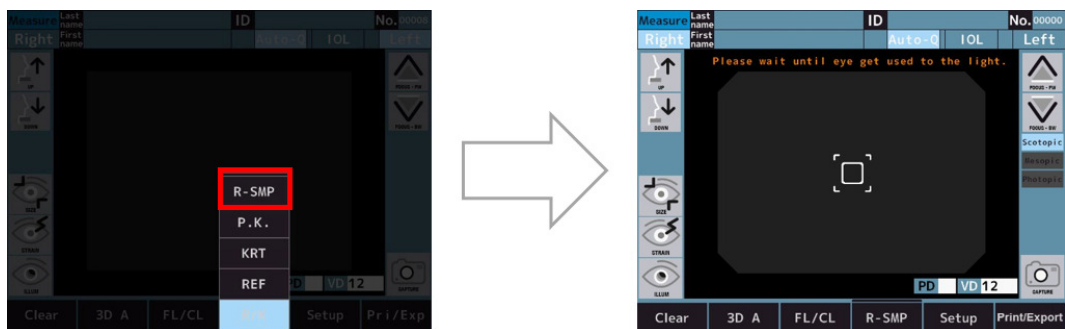

- 2 Scotopic: Wait until the eye gets used to the light.
 - > Scotopic: Ref measurement and pupil diameter estimation for both eyes.

- After the measurements are completed, it automatically switches to the mesopic measurement.

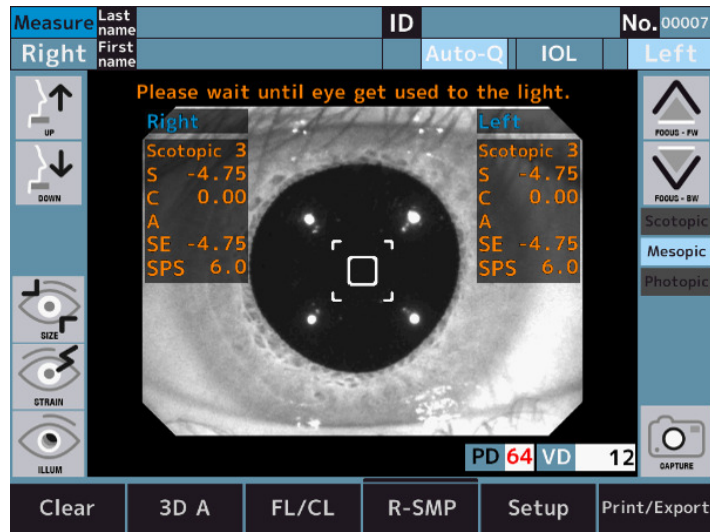

Scotopic > Mesopic: Change brightness of target.

- Mesopic: Wait until the eye gets used to the light.
 - > Mesopic: Ref measurement and pupil diameter estimation for both eyes.
- After the measurements are completed, it automatically switches to the photopic measurement.

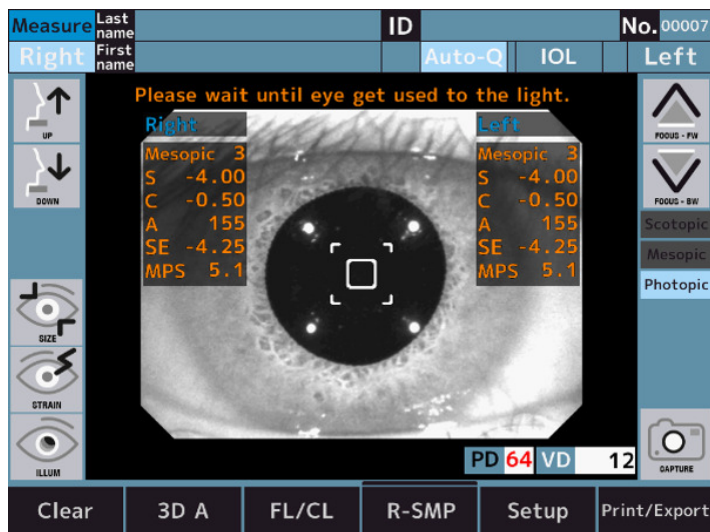

Mesopic > Photopic: Change brightness of the target.

- 6 Photopic: Wait until the eye gets used to the light.
 - > Photopic: Ref measurement and pupil diameter estimation for both eyes.
 - > The graph switches appear.

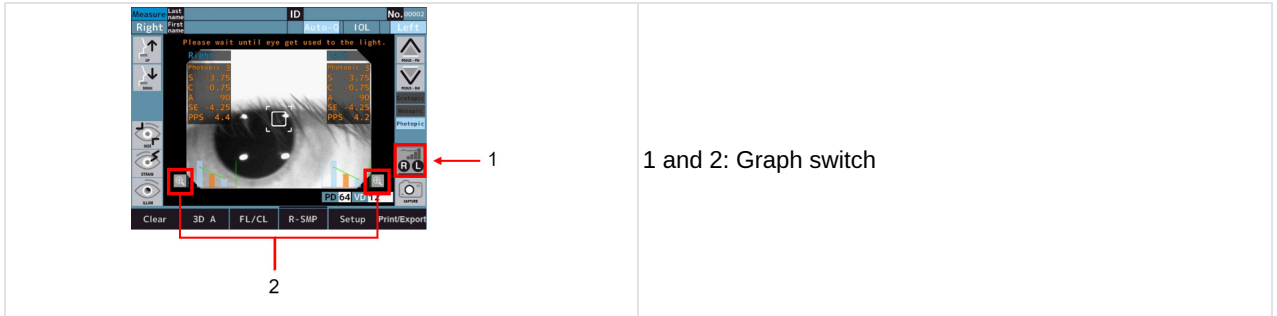

1 and 2: Graph switch

- > The graph is displayed at the bottom of the screen after measurements.
- > The graph is enlarged by touching the graph switches.

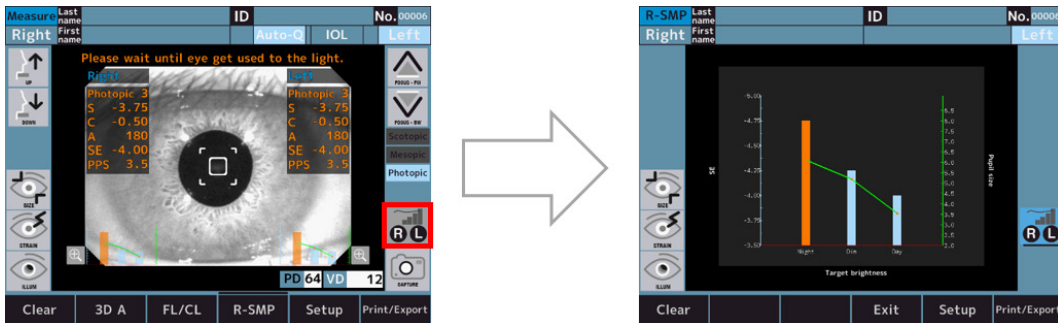

Graph specifications

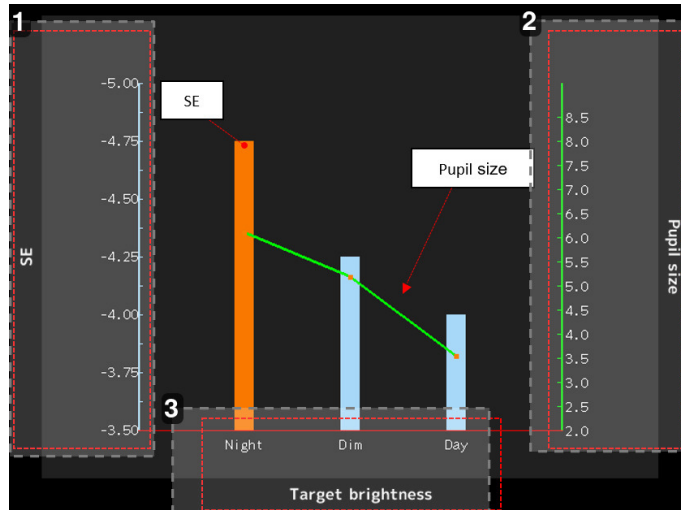

1. Indication of the [SE] value (unit: diopter)

The bar graphs show the [SE] value.

The bar graphs of [Night] and [Dim] are displayed in orange if difference is 0.25D compared to [Day].

2. Indication of the pupil diameter value (unit: mm)

The line graphs show the pupil diameter value.

3. Indication of the measurement mode

- o [Night]: Scotopic
- o [Dim]: Mesopic
- o [Day]: Photopic

c. [WTW]

- 1 Touch the corneal diameter measurement mode switch to enter the corneal diameter measurement screen.

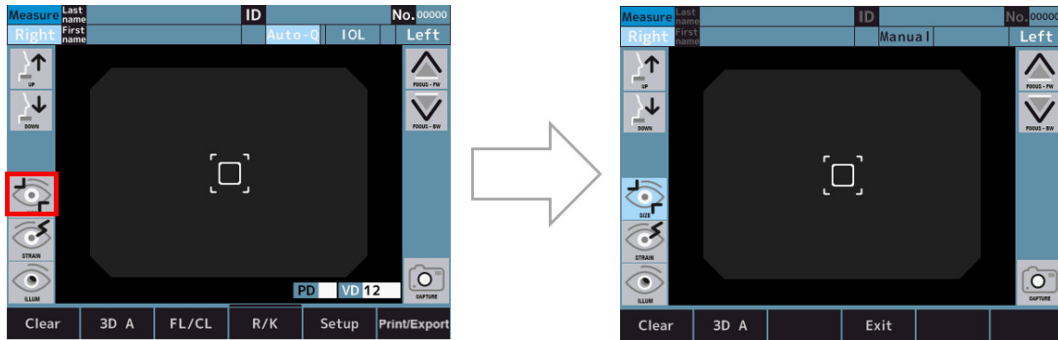

- 2 The alignment image is saved by touching the capture switch after alignment is completed.
 - > The measurement switch is displayed after the image is saved.

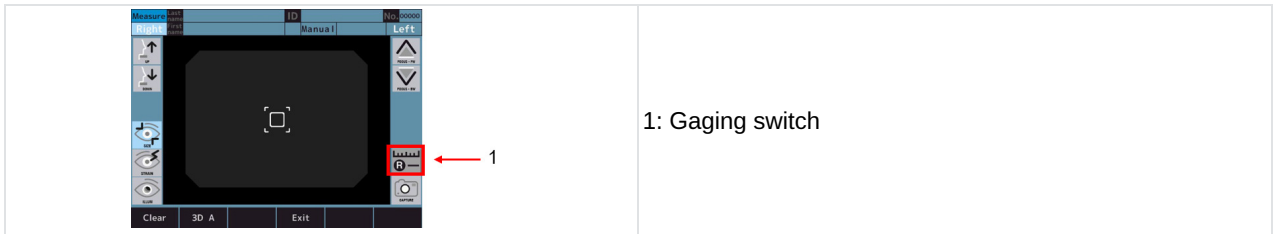

The last alignment image is already saved if the measurement of [REF] or [KRT] etc. is done before corneal diameter measurement.

- 3 The saved image is displayed on the gaging screen which can be entered by touching the gaging switch.

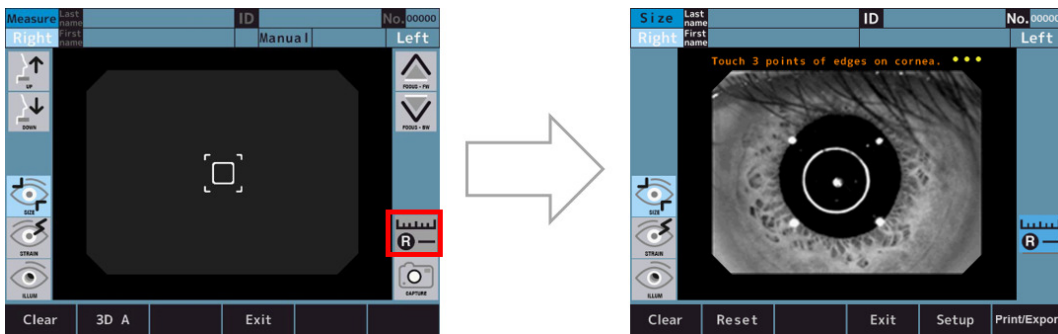

- 4 Measure the corneal diameter by following the measurement procedure below.
 - o By touching the 3 points on the edge of the cornea, the circle which connects the 3 points and the center point which connect the 3 points, and corneal diameter are displayed.
 - o The size of the circle can be changed by touching the circle size adjustment switches.
 - o The position of the circle can be changed by touching the circle position adjustment switches.
 - o The procedure can be redone from [I] by touching the [Reset] switch.

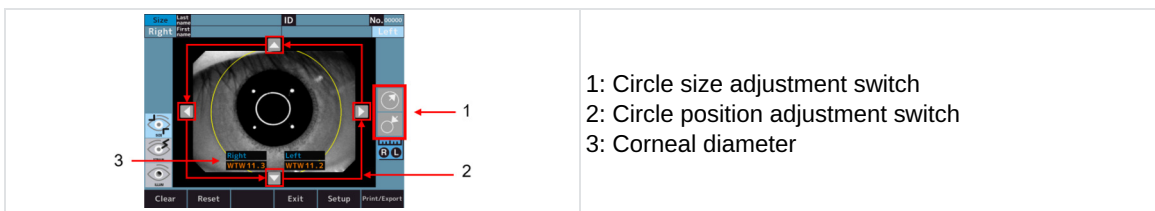

- 1: Circle size adjustment switch
- 2: Circle position adjustment switch
- 3: Corneal diameter

d. Accommodation (optional feature, only available on the AKR800NV commercial offer)

1 Switch to the accommodation measurement mode screen.

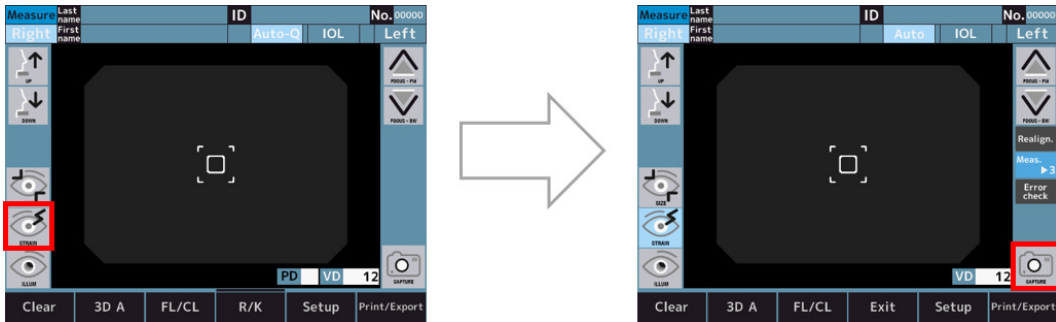

2 The alignment is performed, and the accommodation measurement is started by touching measurement start switch.

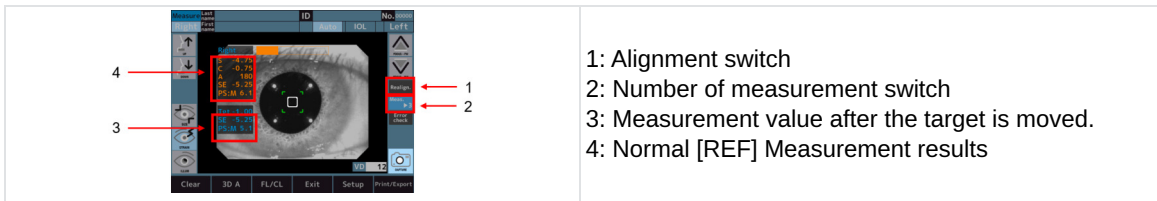

- > After the measurements, the graphs are displayed at the bottom of the screen.
- > The graph can be enlarged by touching the graph switch.

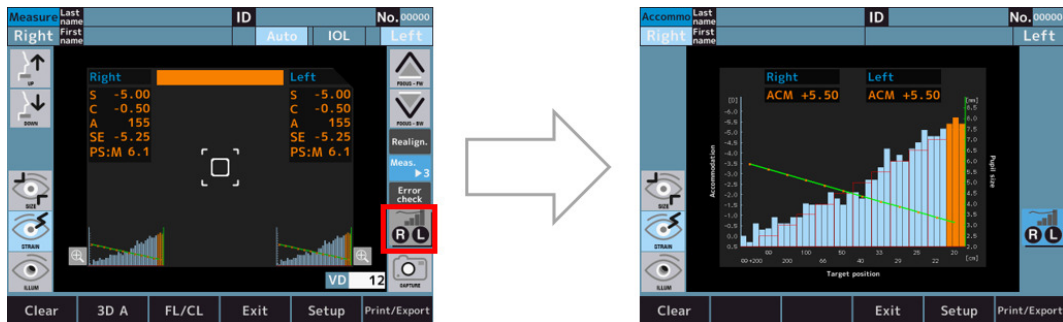

- > By touching the graph, the color of the touched area turns to orange and the [ACM] value at the area is displayed.

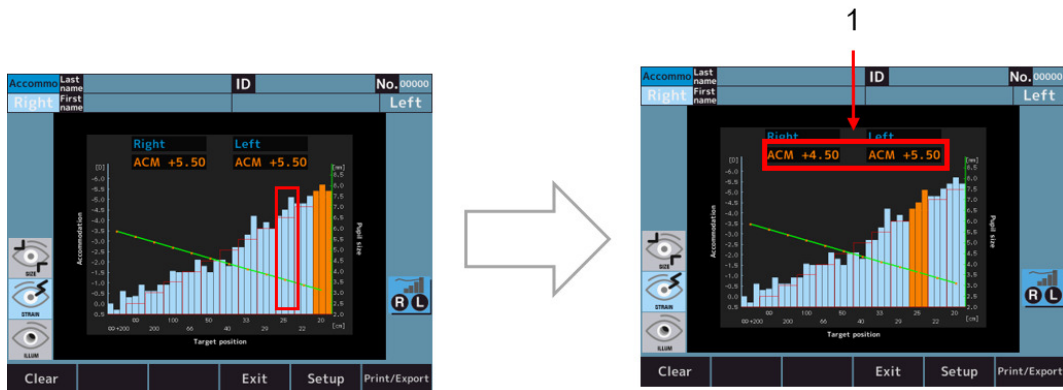

With 1: Accommodation measurement value.

The [ACM] value is calculated as follows:
 $ACM = (SE \text{ value of the starting position of the fixation chart position}) - (SE \text{ value of the bar graph in the orange position})$

Graph specifications

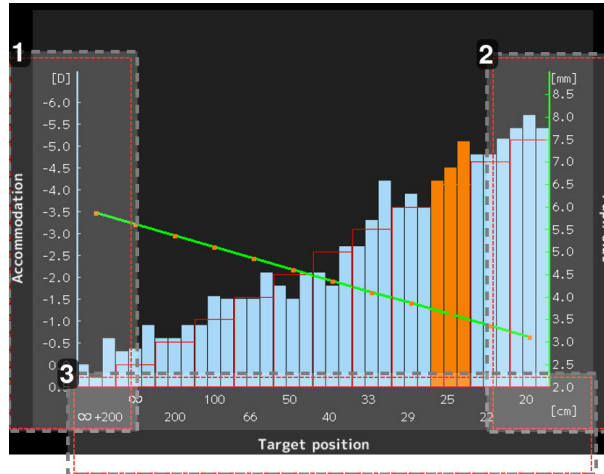

1. Indication of [SE] value (unit: diopter)
The bar graphs show the [SE] value.
2. Indication of pupil diameter value (unit: mm)*
The line graphs show the pupil diameter value.
3. Indication of target position value (unit: cm)
 - o ∞ : Same target position as in normal REF measurement
 - o 20 : Equivalent to 5[D]

*The value displayed is informative.

The practitioner is recommended to get more accurate information by using a device intended by its manufacturer to directly measure these parameters.

e. Retro Illumination (optional feature, only available on the AKR800NV commercial offer)

- 1 By touching the retro illumination mode switch, it enters the retro illumination mode and performs the alignment.

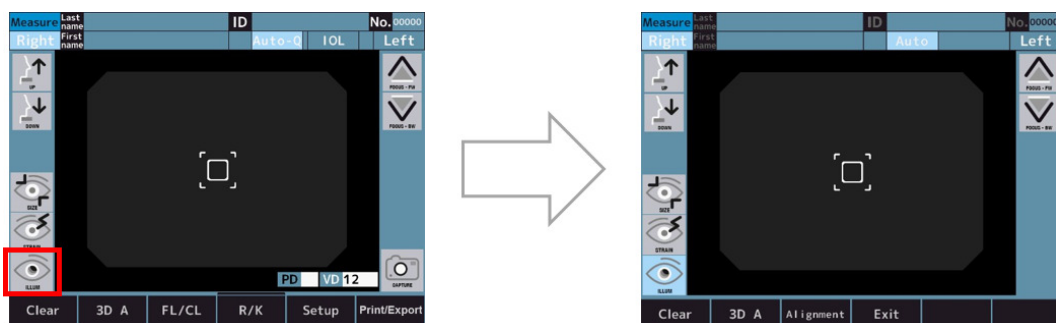

- 2 If the alignment is OK, it enters the observation mode automatically.
- > The modes between alignment and observation can be switched by touching mode selector switch.

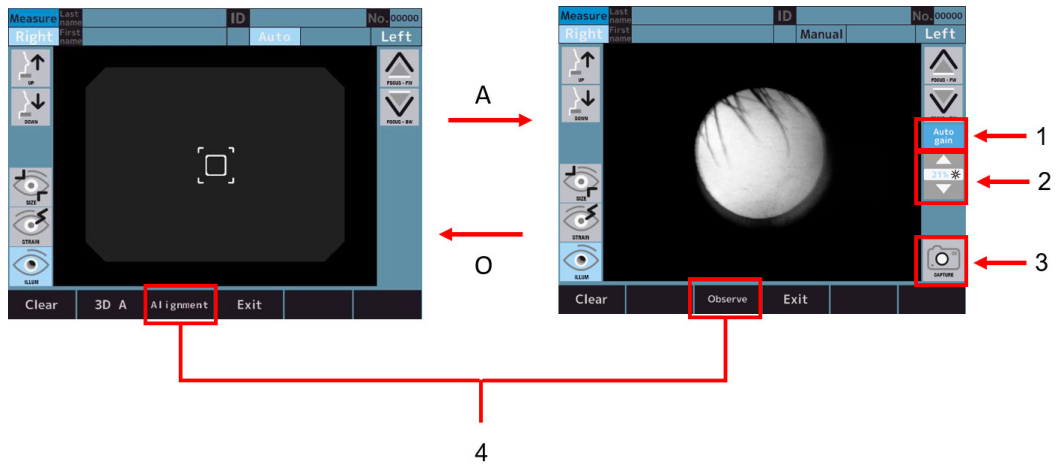

With:

- 1: [Auto gain] switch
- 2: LED intensity adjustment switch
- 3: [Capture] switch
- 4: Mode selector switch



- o When the [Auto gain] switch is active, the light level is adjusted automatically.
- o When the [Auto gain] switch is inactive, the light quantity can be adjusted manually with the LED intensity adjustment switch.

- 3 The captured image is displayed and saved by touching the capture switch.



- 4 Touch one of the Cataract diagnosis level switch to zoom in at the selected level (here example if selection of level 2).

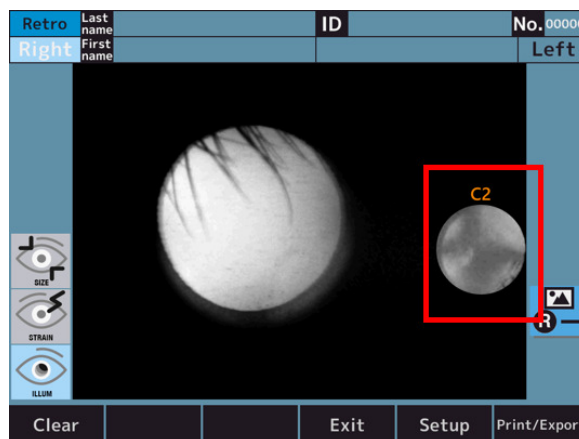

- 5 Touch the enlarged icon to return to the original screen.

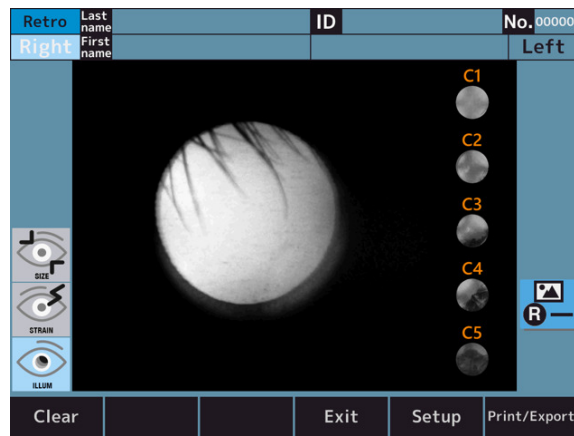

VII. SETTING OF FUNCTION ON [SETUP] SCREEN



1. Operation Procedure on [Setup] screen

Tap the [Setup] switch on the LCD touch panel in the measurement mode.

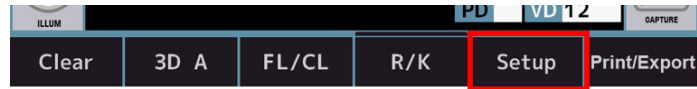

> The [Setup] screen is displayed.

2. List of setup items

The setup consists of 6 tabs, and the items in the Setup are divided according to the setting items.

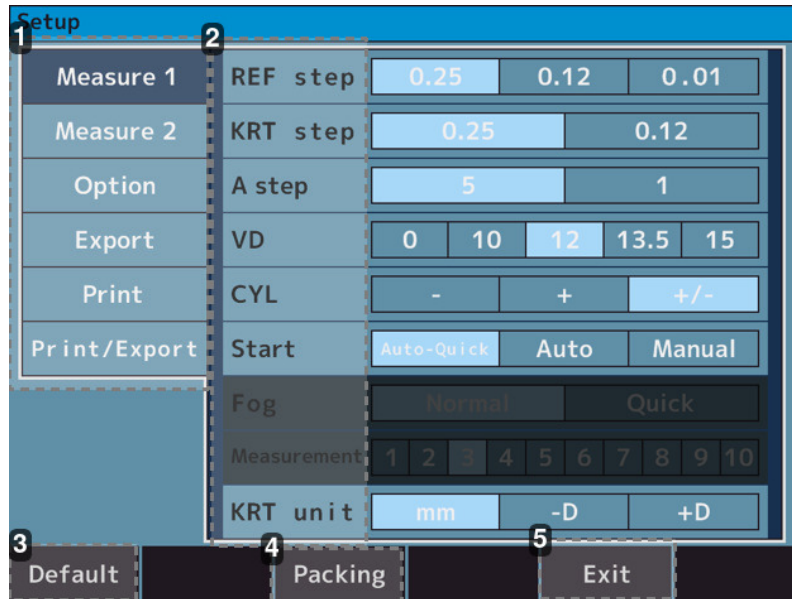

1. Tabs

- [Measure 1] tab: Contains the setting items regarding the operations on the measurement screen and the analysis screen.
- [Measure 2] tab: Contains the setting items regarding the operations on the measurement screen and the analysis screen.
- [Option] tab: Contains the setting items regarding the operations of the common settings.
- [Export] tab: Contains the setting items regarding the data output with external devices.
- [Print] tab: Contains the setting items regarding printout output from the printer. P
- [Print/Export tab]: Contains the setting items regarding Print/Export common.

2. Setting item

3. [Default] switch

The settings in setup are changed back to the factory default.

4. [Packing] switch

The device is changed to the state that is able to be packed in the packing box.

5. [Exit] switch

The setting content is stored, and it is switched to the measurement mode.



Before packing this device in the packing box, change the state to be packed by tapping the [Packing] switch. If this device is packed without changing it to the packing state, it can result in malfunction.

3. [Setup] screen - [Measure] tab

a. [Setup] screen - [Measure 1]

It contains the settings regarding the operations on the measurement screen and the analysis screen.

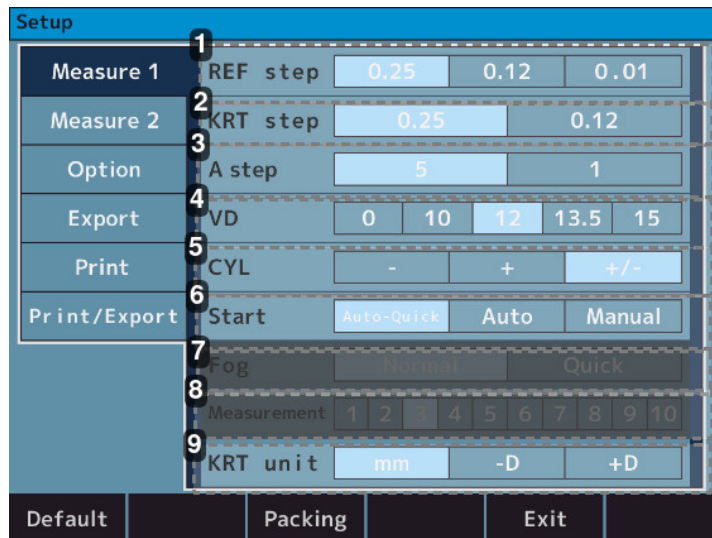

1. [REF step]

- [0.25]: Select the step 0.25 for Sphere and Cylinder.
- [0.12]: Select the step 0.12 for Sphere and Cylinder.
- [0.01]: Select the step 0.01 for Sphere and Cylinder.

2. [KRT step]

- [0.25]: Select the step 0.25 for K1/K2 and Cylinder.
- [0.12]: Select the step 0.12 for K1/K2 and Cylinder.

3. [A step]

- [5]: Select the step 5 for Axis angle.
- [1]: Select the step 1 for Axis angle.

4. [VD]

- [0]: Select 0 for the corneal [Vertex] distance.
- [10]: Select 10 for the corneal [Vertex] distance.
- [12]: Select 12 for the corneal [Vertex] distance.
- [13.5]: Select 13.5 for the corneal [Vertex] distance.
- [15]: Select 15 for the corneal [Vertex] distance.

5. [CYL]

- [-]: Select the sign - of cylindrical value.
- [+]: Select the sign + of cylindrical value.
- [+/-]: Select the sign +/- of cylindrical value.

6. [Start]

- [Auto-Quick]: It starts measurement when the alignment is achieved. Take 1 time of Kerato measurement and 3 times of refractive measurements continuously for each eye.

The result is printed out automatically when Auto [Print/Export] tab) is set as On. (For the refractive measurement, only one time of the fog control is done at the beginning.)

- [Auto]: Take 3 times of Kerato measurements and refractive measurements continuously for each eye.

The result is printed out automatically when Auto [Print/Export] tab) is set as On. (For the refractive measurement, the fog control is done every time).

- [Manual]: Measurements are taken every time the measurement switch is touched.

7. [Fog]

- [Normal]: A measurement is taken once by touching the measurement start switch.
- [Quick]: Continuous measurement is started as much as it is set by touching the measurement start switch once. (Maximum of 10 times).
(For the refractive measurement, only once fog control is done at the beginning).

8. [Measurement]

- 1 to 10: Select the number of measurements when measuring with [Fog- Quick].

9. [KRT]

- [mm]: Corneal Curvature radius.
- [-D]: Corneal astigmatism (-).
- [+D]: Corneal astigmatism (+).

b. [Setup] screen - [Measure 2]

It contains the settings regarding the operations on the measurement screen and the analysis screen.

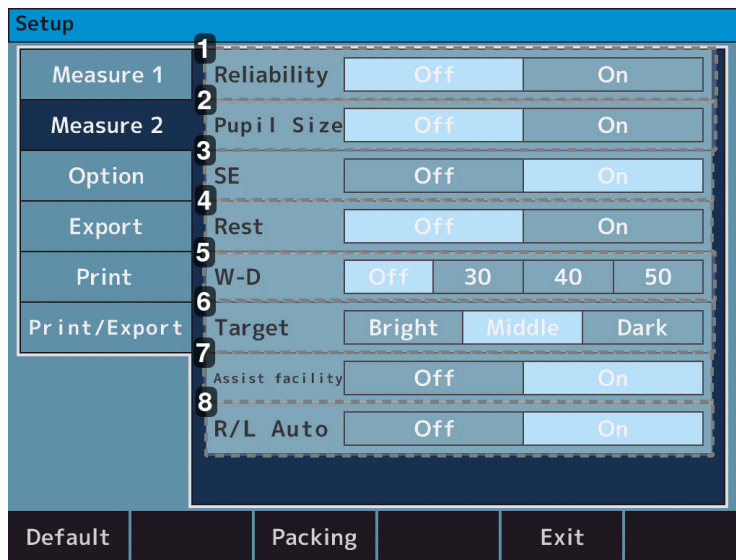

1. [Reliability]

- [Off]: No low reliability mark is displayed.
- [On]: If it is judged that the measurement value possesses low reliability, display the low reliability mark [*] on it.

2. [Pupil size]

- [Off]: Pupil diameter estimation is not printed out.
- [On]: Pupil diameter estimation is printed out.

3. [SE]

- [Off]: No output of [SE] value.
- [On]: Output the representative value of [SE] on printout, data screen and communication output.

4. [Rest]

- [Off]: Residual astigmatism is not printed out.
- [On]: Residual astigmatism is printed out.

5. [W-D]

- [Off]: Do not set the working distance.
- [30]: The near pupil distance (30cm ahead) is automatically computed after the estimation and displayed on the screen.
- [40]: The near pupil distance (40cm ahead) is automatically computed after the estimation and displayed on the screen.

- [50]: The near pupil distance (50cm ahead) is automatically computed after the estimation and displayed on the screen.

6. [Target]

- [Bright]: Brighten the target.
- [Middle]: Normal setting.
- [Dark]: Darken the target.

7. [Assist facility]

- [Off]: The comment assisting alignment is not displayed.
- [On]: The comment assisting alignment is displayed.

8. [R/L Auto]

- [Off]: The right and left eyes are not switched automatically.
- [On]: The optical head automatically moves to the position measuring the opposite eye

4. [Setup] screen - [Option] tab

It contains the settings regarding the operations of the common settings.

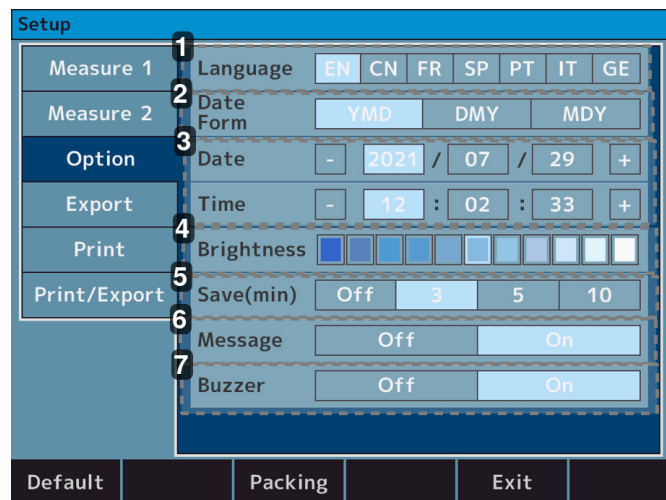

1. [Language]

- EN > Set the language to English.
- CN > Set the language to Chinese.
- FR > Set the language to French.
- SP > Set the language to Spanish.
- PT > Set the language to Portuguese.
- IT > Set the language to Italian.
- GE > Set the language to German.

2. [Date form]

- [YMD] > Set the order of the date printed to year/month/day.
- [DMY] > Set the order of the date printed to day/month/year.
- [MDY] > Set the order of the date printed to month/day/year.

3. [Date] & [Time]

Set the date and time.

4. [Brightness]

- Indication with 11 levels > Set the light intensity of the LCD touch panel.

5. [Save (min.)]

- o [Off]: Sleep mode is not used.
- o [3]: Switched to sleep mode 3 minutes after the operation is finished.
- o [5]: Switched to sleep mode 5 minutes after the operation is finished.
- o [10]: Switched to sleep mode 10 minutes after the operation is finished.

6. [Message]

- o [Off]: Message is not printed out.
- o [On]: Switched to the message input screen. The message is printed out.

7. [Buzzer]

- o [Off]: Buzzer is not activated.
- o [On]: Buzzer is activated.

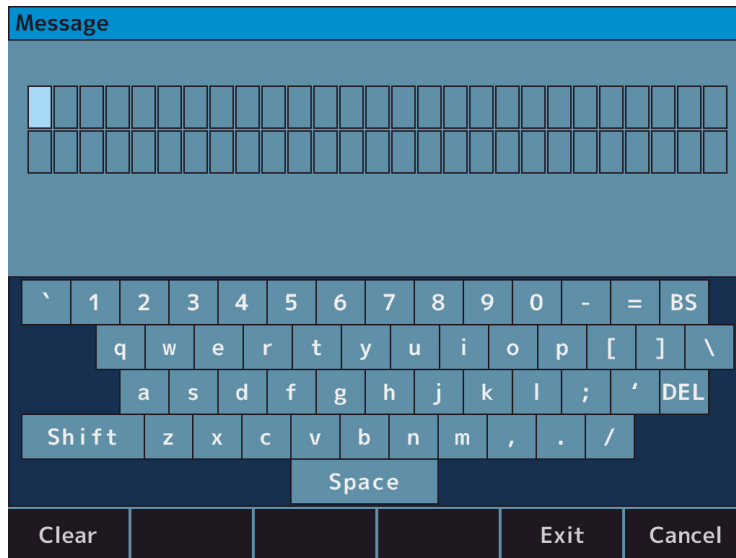

The input screen is displayed by tapping the message. The letters can be set up to 27 letters x 2 lines.

5. [Setup] screen - [Export] tab

It contains the settings regarding the data output with external devices.

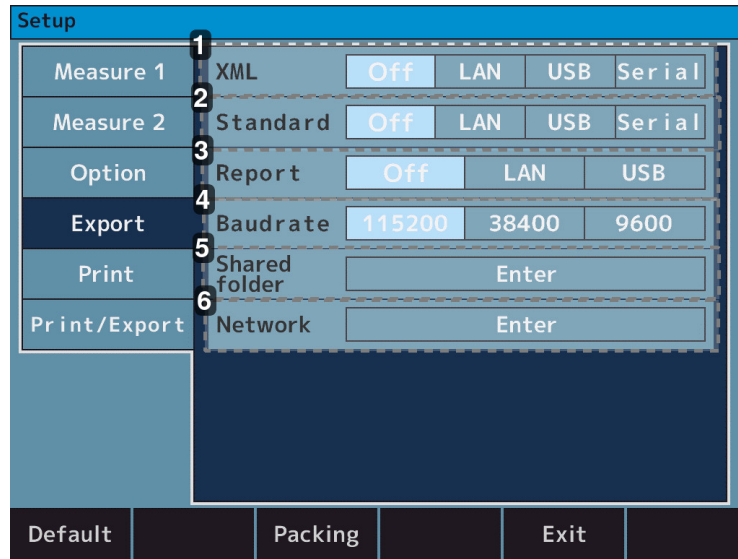

1. [XML]

- [Off]: Measurement result is not output in XML format.
- [LAN]: Measurement result is output in XML format through LAN connector.
- [USB]: Measurement result is output in XML format through USB-A connector.
- [Serial]: Measurement result is output in XML format through RS-232C connector.

2. [Standard]

- [Off]: Measurement result is not output in Essilor format.
- [LAN]: Measurement result is output in Essilor format through LAN connector.
- [USB]: Measurement result is output in Essilor format through USB-A connector.
- [Serial]: Measurement result is output in Essilor format through RS-232C connector.

3. [Report]

- [Off]: Measurement result is not output in jpeg format.
- [LAN]: Measurement result is output in jpeg format through LAN connector.
- [USB]: Measurement result is output in jpeg format through USB-A connector.

4. [Baudrate]

- [115200]: The data transfer rate when using "Serial" is 115200bps.
- [38400]: The data transfer rate when using "Serial" is 38400bps.
- [9600]: The data transfer rate when using "Serial" is 9600bps.

5. [Shared folder]

Shared folder is set.

6. [Network]

IP address is set.



For the connection to PC through RS-232C connector:

- Character is set to 8 bits
- Parity is set to NONE
- Stop bit is set to 1 bit

They cannot be changed, fixed within the device.

a. [Shared folder] - [Setting] screen

The shared folder is set.

- [Shared folder]: 64 letters
- [User]: 15 letters
- [Password]: 16 letters



- The user name should be different from the computer name.
- The following symbols cannot be entered for each item.
 - Folder : 『 : * \ / ? " < > | 』
 - User : 『 \ / : ; * ? " < > | [] + = , . % @ 』
 - Password : 『 : * \ ? " < > | 』

b. [Network] - [Setting] screen

1. [IP setting type]
 - [DHCP]: IP address is assigned automatically by DHCP server.
 - [Manual]: IP address is set manually.
2. [IP address]

IP address of this device is set.

3. [Subnet mask]

Subnet mask of this device is set.

4. [Default gateway]

Default gateway is set.

5. [Primary DNS server]

Number of primary DNS server is set.

6. [Secondary DNS server]

Number of secondary DNS server is set.

* Network info. redisplay switch



Confirm that this device and PC which the data is output to are in the same network, and it is operated as SFTP server.

Data may not be output depending on the firewall settings, etc. If communication is not successful, contact your network administrator.

6. [Setup] screen - [Print] tab

It contains the settings regarding the printout output from the printer.

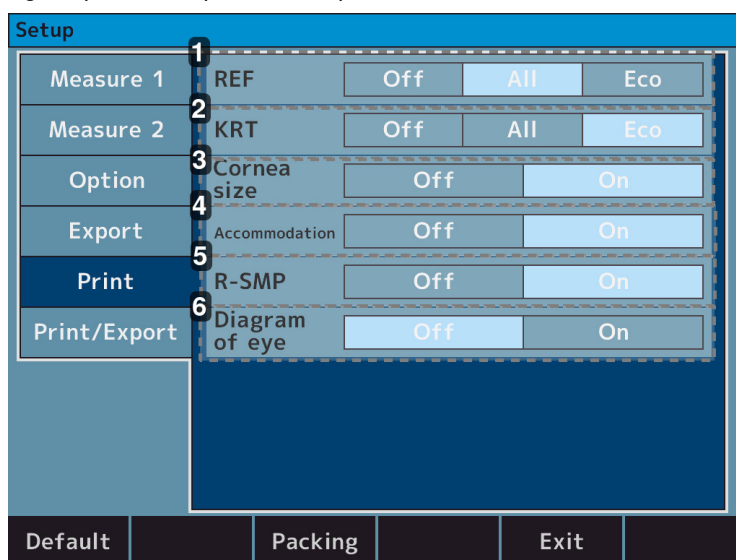

1. [REF]

- [Off]: No REF measurement result is printed out.
- [All]: Print out all of the [REF] measurement. (Maximum of 10 times for each eye).
- [Eco]: Print out only the optimum values for the [REF] measurement.

2. [KRT]

- [Off]: No Kerato measurement result is printed out.
- [All]: Print out all of the Kerato measurement. (Maximum of 10 times for each eye).
- [Eco]: Print out only the optimum values for the Kerato measurement.

3. [Cornea size]

- [Off]: No [WTW] measurement result is printed out.
- [On]: [WTW] measurement result is printed out.

4. [Accommodation] (optional feature, only available on the AKR800NV commercial offer)

- [Off]: No Accommodation measurement result is printed out.
- [On]: Accommodation measurement result is printed out.

5. [R-SMP]

- [Off]: No [R-SMP] measurement result is printed out.
- [On]: [R-SMP] measurement result is printed out.

6. [Diagram of eye]

- [Off]: No Diagram of eye is printed out.
- [On]: Diagram of eye is printed out.

7. [Setup] screen - [Print/Export] tab

It contains the settings regarding [Print/Export] common.

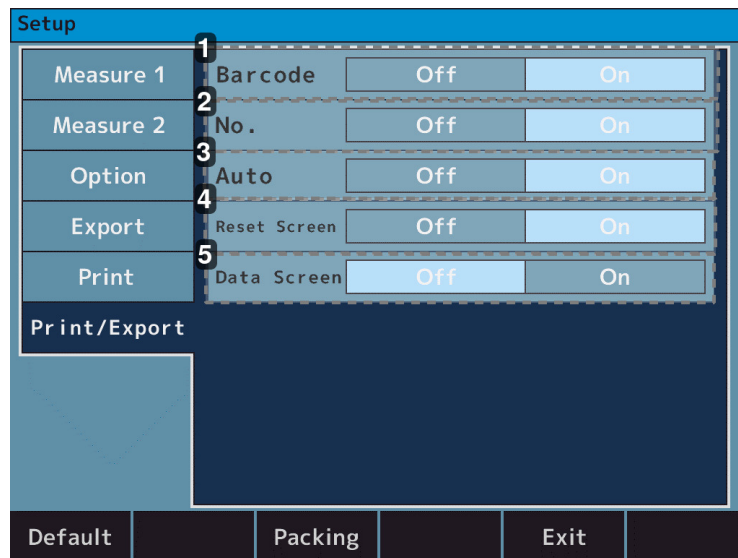

1. [Barcode]

- [Off]: Barcode is not printed out.
- [On]: Barcode is printed out.

2. [No.]

- [Off]: No. is not printed out.
- [On]: No. is printed out.

3. [Auto]

- [Off]: Deactivate the auto print function.
- [On]: Activate the auto print function.

4. [Reset screen]

- [Off]: Leave the measurement values on the screen after printout.
- [On]: Delete the measurement values on the screen after printout.

5. [Data screen]

- [Off]: Display no measurement result on the screen.
- [On]: Display the measurement results on the screen.

VIII. MAINTENANCE

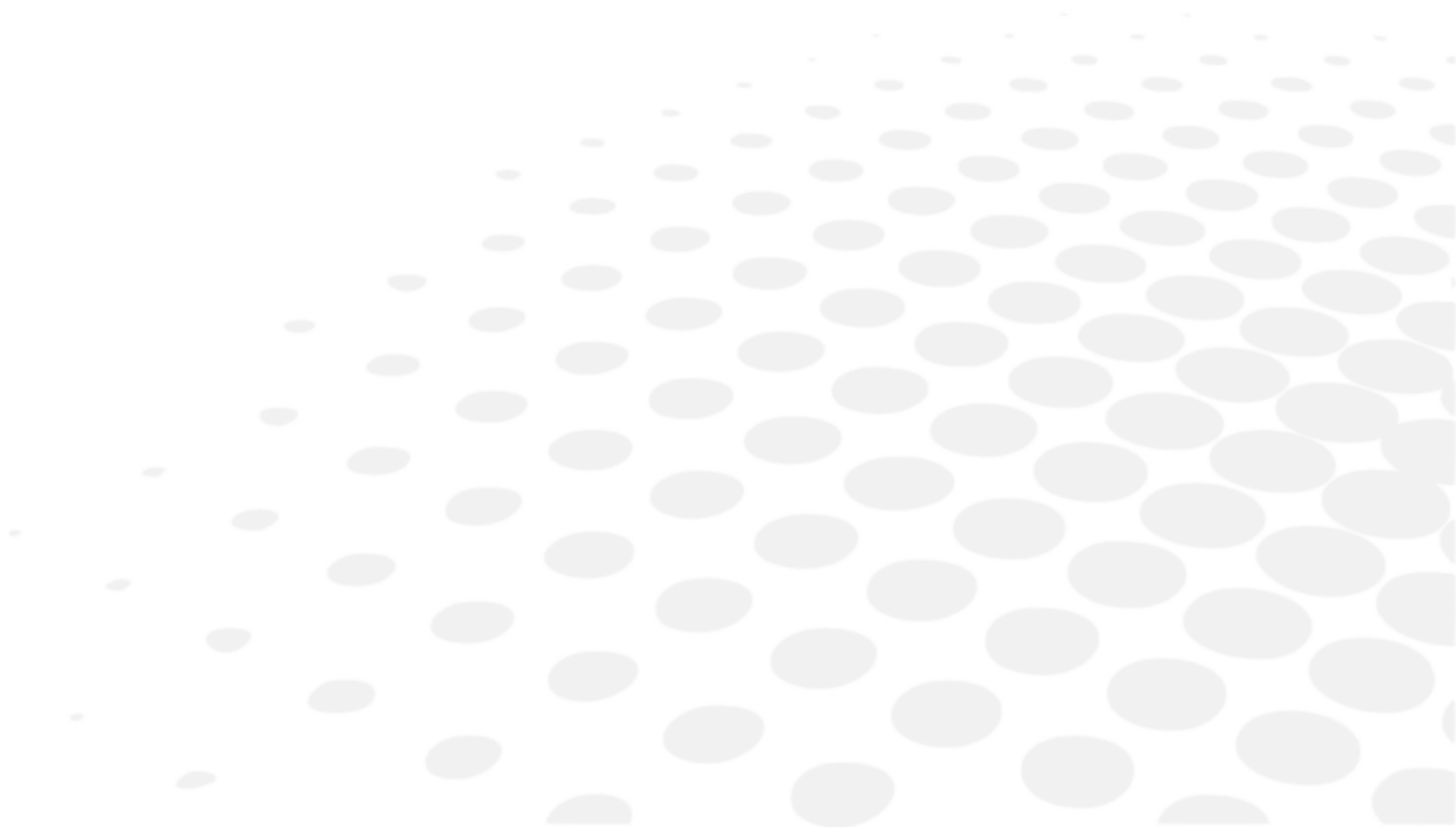



The circuit diagram, parts lists, descriptions and instructions for calibration and testing are available separately from this manual.

1. Storage and handling condition



Respect the operating, storage and transport conditions noted below.



Avoid condensation conditions.



The original packaging of this device complies with EN ISO 15004-1.

	Temperature	Humidity	Atmospheric pressure
Use	[10°C; + 35°C]	[30 %; 90%]	[800 hPA; 1060 hPA]
Storage	[-10°C; + 55°C]	[10 %; 95%]	[700 hPA; 1060 hPA]
Transport	[-40°C; + 70°C]	[10 %; 95%]	[500 hPA; 1060 hPA]



Do not store the product:

- Where dust accumulates.
- Where water may get on the unit.
- Where temperature and humidity are out of the specified ranges.
- Where there is direct contact with sunlight.
- In a unstable and high place.



Check the following items in case the device is not used or is stored for a long time.

Points to check for long-term storage

- Turn off the power.
- Remove the power cord from the outlet.
- Place the main unit undermost.
- Secure the main unit by locking the slide lock of the main unit.
- Put the dust cover on the main unit. If dust adheres, it will affect the measurement.

a. Disassembly of the product and transport



At the time of conveyance, the base unit of the device should be held with both hands by two or more people.

Otherwise, it can result in injury due to dropping of the device.

At the time of conveyance, the base unit of the device should be held securely with both hands by two or more people. Do not hold the headrest, chinrest or control panel because it can result in deformation or breakage of the device.

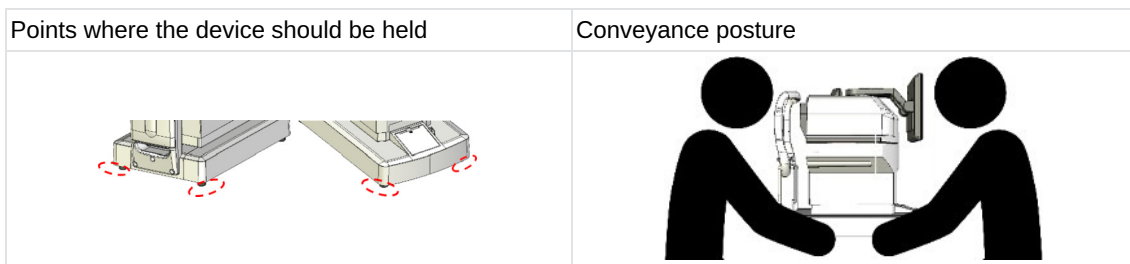

b. Conveyance

Make sure to set as package mode when transporting the device. After turning On the power, press the [Packing] button on the setting screen to enter the package mode.

The product will then return to its parked position.



- At the time of conveyance, hold the back and front of the base unit (the cutout of the front side and the handle under the chinrest) with both hands securely. Do not hold the headrest, chinrest or LCD monitor because it can result in deformation or malfunction.
- Do not drag the power cord while it is attached to the main unit. It can result in malfunction of the device or personal injury caused by fall or drop if the cord is stuck or stepped on.



Great care should be taken because the measurement cannot be carried out if the examinee is exposed to strong light or glare during the measurement and his/her pupil contracts too small.

- Do not use in long-time in an environment under high temperatures. The applied parts will rise to 42°C.
- Do not expose the view window of the device directly to the sunlight or bright lighting from other sources.

c. Replacement of fuse



- At the time of fuse replacement, unplug the power cord from the unit before removing the fuse holder.
- If removing the fuse holder without unplugging the power cord, it can result in electric shock.

- 1 Confirm that the power of the main unit is off, and the power cord is unplugged.

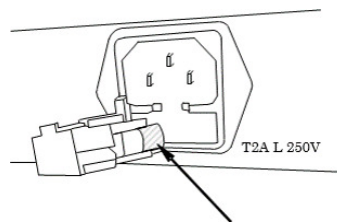

- 2 Remove the power fuse holder.
- 3 Replace with a fuse of the same rating as the built in product.



Always use the specified fuse (T2A L 250V).

- 4 Attach the fuse holder by squeezing it in.

d. Refill of chinrest liner



- For sanitary reasons, dispose the top chinrest liner after every patient.
- For sanitary reasons, disinfect the chinrest with ethanol for disinfection.

> Ethanol for disinfection contains 76.9 to 81.4vol% of ethanol (C₂H₆O) at 15°C (specific gravity).

- 1 When refilling the chinrest liner, pull out the chinrest liner pins and refill it.

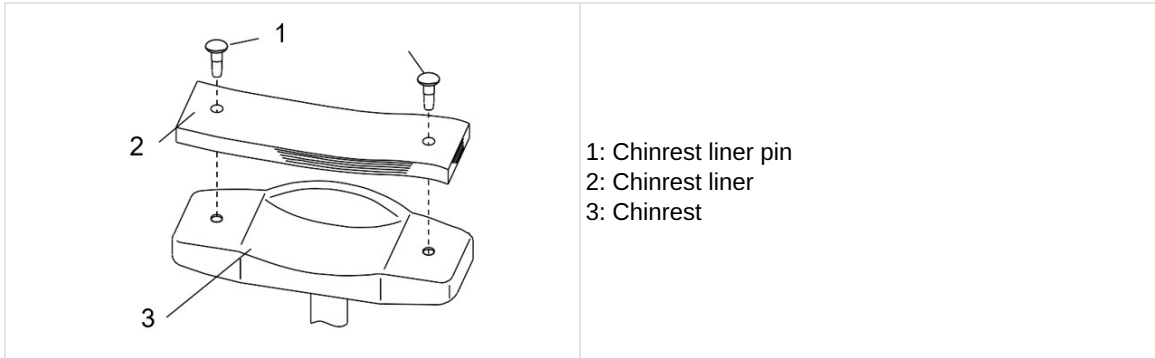

- 2 After that, fix it with the pins again.

2. Cleaning instructions



Unplug the device and check that it is not powered.

a. Cleaning of headrest and chinrest



When the headrest and chinrest get dirty, clean them with a neutral cleanser.

When reusing, disinfect the parts especially those that came into contact with the examinee and use such as the chinrest and headrest, use ethanol for disinfection.

- Ethanol for disinfection contains 76.9 to 81.4vol% of ethanol (C₂H₆O) at 15°C (specific gravity).
- The device returned to the manufacture for repair and maintenance is also disinfected using the same method.



- Do not spray chemicals on the device when disinfecting. If they get inside the device, it can cause malfunction.
- It is not necessary to replace the chinrest and headrest.
> Chinrest and headrest comply with ISO 10993-1.
- Do not use organic solvents such as thinners which will dissolve the surface of the device. It can result in deterioration, breakage or injury.

b. Cleaning of external cover

- When the external covers get dirty, gently wipe them with a dry cloth.
- For stubborn stains on the external covers, it is recommended to clean them with a little water or neutral cleanser.



Avoid using organic solvents such as thinner because it can result in tarnish or transformation due to dissolving of surface.

c. Cleaning of LCD touch panel

1. If dust is adhered, gently wipe it with monitor cleaner etc. after brushing it off with a soft brush etc.
2. If a fingerprint etc. is there, gently wipe it with monitor cleaner etc.



Wipe the LCD touch panel after turning power off because it is the touch panel.

d. Cleaning of measurement window glass

If the measurement window glass gets dirty, auto alignment might not work. If it gets dirty, gently wipe it with a soft cloth. At this time, take care not to scratch it.



If a finger print or dust adhered on the optical parts, gently wipe it with a soft cloth with great care. Do not scratch it.

3. Periodical inspection and maintenance

To prevent malfunction and accidents and maintain the performance and reliability of the product, it is recommended to request your distributor that a periodical inspection and maintenance is done once a year.

The periodical inspection and maintenance include the inspection of the function and performance of the product, as well as cleaning, adjustment and replacement of consumable parts if necessary.

It is recommended for the distributors to perform the cleaning of each part, performance check and accuracy check at least once in a year.

- Cleaning of each part: exterior parts and optical system
- Performance check: main unit and each switch
- Accuracy check: measurement function of refractive power and corneal curvature radius



- Do not perform any maintenance when used with a patient.
- This device is a precision optical device.
> Always handle it with care and do not drop it.



- Do not touch the optical parts such as the glass of the view window with your hands and be sure to avoid dust because auto alignment and its measurement accuracy could be adversely affected.
- When the device is not in use, protect it with the supplied dustproof cover. If dust adheres to it, it affects its measurement accuracy.



If the device is not used for a long time, remove the power cord from the outlet.

4. Confirmation of measurement accuracy

It is extremely important to check operation and accuracy of the device with the supplied model eye. We recommend checking its accuracy periodically.

If the measurement result of the model eye is within the tolerance listed below, the measurement is considered reliable and accurate. If the result exceeds the tolerance, contact your dealer immediately.

Model eye data		
SPH	CYL	R
Indicated value ± 0.25	0 ± 0.25	Indicated value ± 0.03



The precise value of the supplied model eye is indicated on the model eye stand (VD=12).

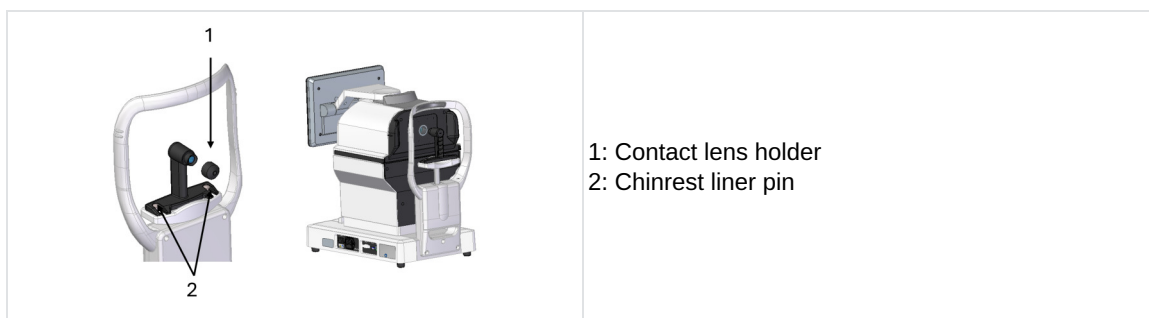

Remove the contact lens holder and set the model eye with the chinrest liner pin carefully, so as not to incline back and forth and around.

If the model eye is inclined, it cannot take [CYL] value data correctly.



Setting of model eye:

- Set the model eye at the position where an alignment mark is located at the center of the reticle mark and the model eye comes into focus.
- When all of the conditions above are met, start the measurement.

IX. ERROR AND TROUBLESHOOTING

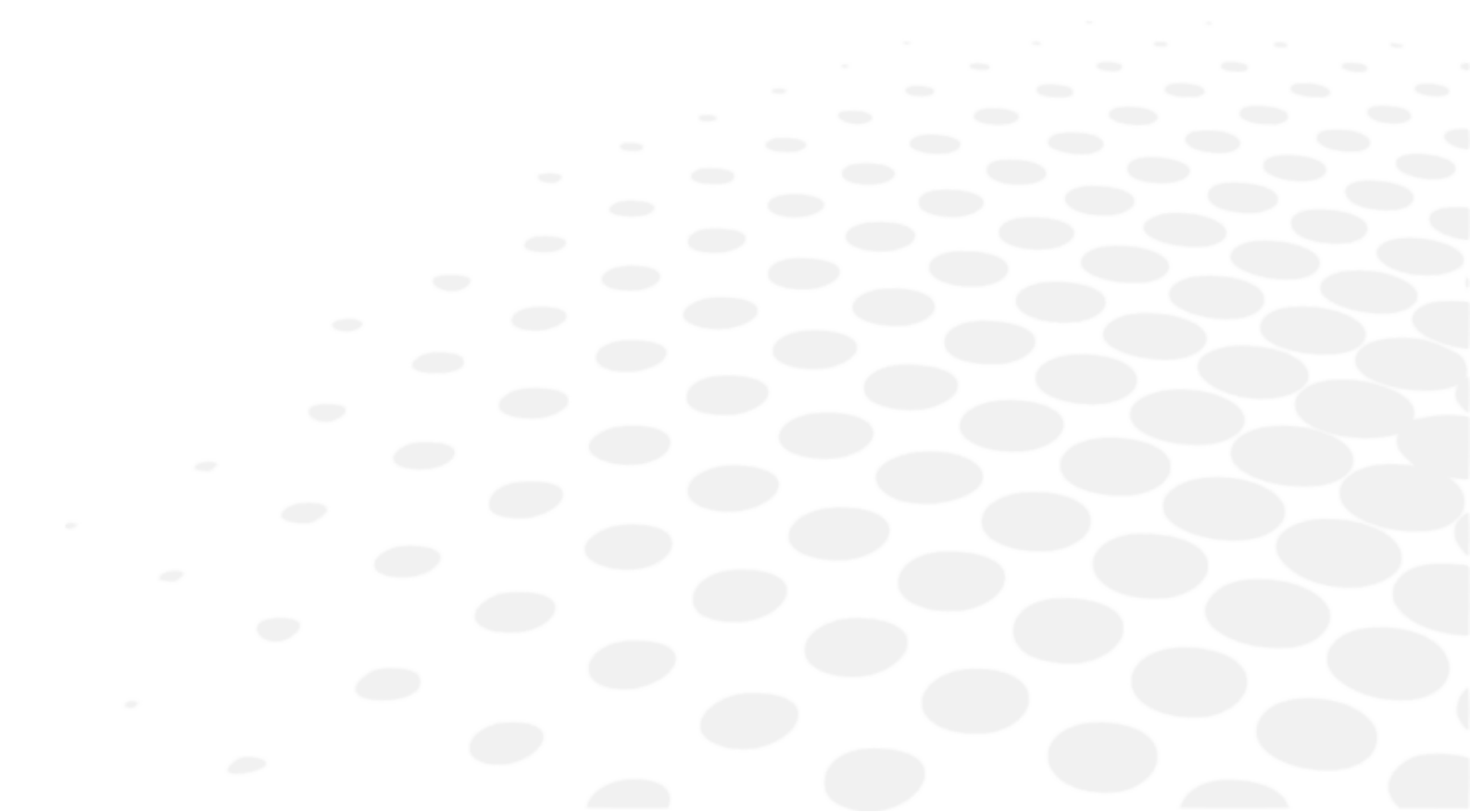

If a problem is detected, refer to the table below in order to take the appropriate measures.

1. Error display

When this device judges that the measurement conditions or measurement results are not reasonable or something is wrong with the performance from the several conditions at the time of measurements, the error messages are displayed in the red frame on the figure on the right.

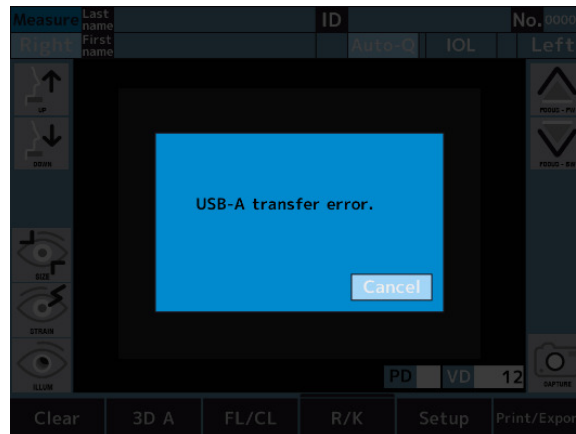

MESSAGE	CAUSES AND PROCEDURE
RETRY	<ul style="list-style-type: none"> Failed to capture eye image because the examinee blinks or moves during measurement or the examined eye has eye diseases : <ul style="list-style-type: none"> Try alignment precisely and conduct measurement again. Consult your dealer immediately if the message appears again. Do not try to repair by yourself.
SPH OVER	<ul style="list-style-type: none"> Exceeded spherical measurement range (-30 to +22D). (In case of VD=0, contact value)
CYL OVER	<ul style="list-style-type: none"> Exceeded cylindrical measurement range (0 to ±10D).
Target motor fault	<ul style="list-style-type: none"> Detected abnormality in motor control system. <ul style="list-style-type: none"> Cycle the power. If this message remains displayed even after that, contact your local distributor. Do not attempt to repair it by yourself.
Focus motor fault	
EEPROM fault	<ul style="list-style-type: none"> Failed to initialize. <ul style="list-style-type: none"> Cycle the power. If this message remains displayed even after that, contact your local distributor. Do not attempt to repair it by yourself.
Sub system data err	<ul style="list-style-type: none"> There is an error in the system. <ul style="list-style-type: none"> Cycle the power. If this message remains displayed even after that, contact your local distributor. Do not attempt to repair it by yourself.
Sub system time out	

Printer cover opened	<ul style="list-style-type: none"> • The printer cover is opened. <ul style="list-style-type: none"> ◦ Close the printer cover. ◦ If this message remains displayed even after closing the cover, contact your local distributor. ◦ Do not attempt to repair it by yourself.
Printer overheated	<ul style="list-style-type: none"> • The printer head is overheated. <ul style="list-style-type: none"> ◦ Cut the power and stop using until the head cools off. ◦ Consult your dealer immediately if the message appears again. ◦ Do not try to repair by yourself.
Paper empty	<ul style="list-style-type: none"> • There is no printer paper. <ul style="list-style-type: none"> ◦ Set the printer paper appropriately.
Please reset the paper	<ul style="list-style-type: none"> • The cutter or printer is not working normally. <ul style="list-style-type: none"> ◦ Set the printer paper again. ◦ If this message remains displayed even after that, contact your local distributor. ◦ Do not attempt to repair it by yourself.
LAN transfer error	<ul style="list-style-type: none"> • Failure of data forward. <ul style="list-style-type: none"> ◦ Check the settings regarding LAN connection.
LAN connection failure	<ul style="list-style-type: none"> • Failure of communication with this device. <ul style="list-style-type: none"> ◦ Check the connection between this device and PC. ◦ If this message remains displayed even after that, contact your local distributor. ◦ Do not attempt to repair it by yourself.
USB-A transfer error	<ul style="list-style-type: none"> • Failure of data forward to USB memory. <ul style="list-style-type: none"> ◦ The USB memory in use might not be able to communicate with this device. ◦ Replace the USB memory, and try to communicate again.
USB-A connection failure	<ul style="list-style-type: none"> • Failure of data forward to USB memory. <ul style="list-style-type: none"> ◦ Check the connection between this device and USB memory. ◦ If this message remains displayed even after that, contact your local distributor. ◦ Do not attempt to repair it by yourself.
Set up fail	<ul style="list-style-type: none"> • An invalid IP address is set. Network address, broadcast address, and loopback address cannot be used. <ul style="list-style-type: none"> ◦ Check the IP address settings. ◦ Use a valid IP address
Network is unreachable	<ul style="list-style-type: none"> • There is no transmission route to the network. This is caused by a misconfigured routing. <ul style="list-style-type: none"> ◦ Check the subnet mask and default gateway settings.

No route to host	<ul style="list-style-type: none"> It indicates a network problem and usually occurs when the host is not responding. It can also be caused by improper firewall or router settings. <ul style="list-style-type: none"> Check if there is a problem with your network. Make sure that the settings of your firewall and router are proper
User or pass is wrong	<ul style="list-style-type: none"> User authentication failed. Either or both of the user name or/and the password is/are incorrect. <ul style="list-style-type: none"> Check your username and password settings.
DHCP fail	<ul style="list-style-type: none"> IP settings could not be obtained by DHCP. The DHCP server settings may be incorrect. <ul style="list-style-type: none"> Check the status and setting of the DHCP server.
DNS fail	<ul style="list-style-type: none"> Name resolution failed. The DNS settings may be incorrect, or there may be a problem with the DNS server. <ul style="list-style-type: none"> Check your DNS settings. Check if the DNS server is running.
Folder name is wrong	<ul style="list-style-type: none"> The set folder name is incorrect. <ul style="list-style-type: none"> Set the name of the existing folder.

If the error messages appear even though there is no system error, check if the examinee has a disease on his/her eye, if there are other possibilities.



If you cannot solve the problem even by following the instructions above, contact your local distributor immediately.

2. Troubleshooting

SYMPTOMS	CAUSES AND MEASUREMENTS
The monitor and power indicator are not on.	<ul style="list-style-type: none"> The plug of the power cord is disconnected from the outlet. The power plug is disconnected from this device. Connect to the outlet securely. A fuse might be blown out. If a fuse is blown out, replace it with a new one.
	<ul style="list-style-type: none"> The fuse is blown out when turning on the power switch. Contact your local distributor immediately.
The screen gets blacked out.	<ul style="list-style-type: none"> The power saving mode might be active. Exit the power saving mode by tapping the LCD touch panel. If the power saving mode is not necessary, change the setting.
Cannot operate touch panel	<ul style="list-style-type: none"> Contact your local distributor immediately.
Difficult to see the LCD touch panel.	<ul style="list-style-type: none"> The screen is dark. Check the brightness of the LCD touch panel.
Abnormality on the moving unit of the main unit.	<ul style="list-style-type: none"> Do not move the unit forcibly. Contact your local distributor.

<p>The data is not printed out.</p>	<ul style="list-style-type: none"> • A paper comes out without printing out. Check the rolling direction of the paper. It might be set inside out. • No paper comes out. The setting of Print might be set as "OFF". Correct the setting of Print. Refill the printer paper if "Paper Empty." is displayed on the LCD touch panel.
<p>The device loses date and time.</p>	<ul style="list-style-type: none"> • The device loses the data and time even if setting them. The battery in the device might be run out. Recharge the battery by keeping the power on for 24 hours.
<p>The packaging of the device is damaged, or the package was unintentionally opened before use.</p>	<p>Check the device for proper operation.</p>

If the problem has not been resolved after taking the measures listed above, contact your local distributor immediately. Your dealer has been trained by Essilor.

X. TECHNICAL DESCRIPTION

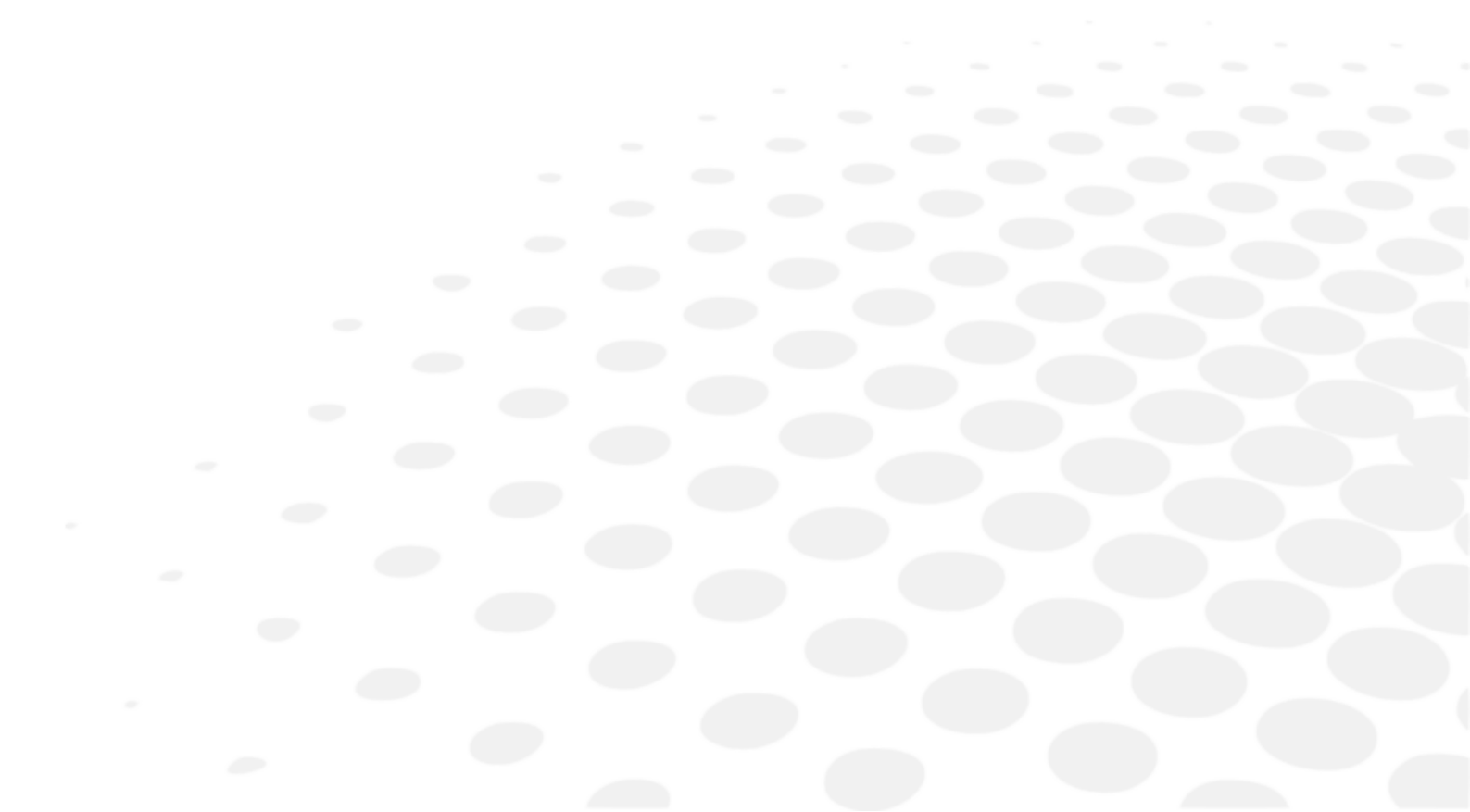

1. Technical data

a. Product lifespan

The expected life of the device and its components is 7 years.

b. Disposal

	<p>Instructions for the disposal of the instrument in accordance with Directives 2012/19/EU and 2011/65/EU regarding the limitation of dangerous substances in electrical and electronic equipment and the disposal of electrical and electronic waste.</p> <p>When it reaches the end of its lifetime, the instrument should not be thrown out with the household refuse. It can be disposed of at a waste management center operated by the municipality or the retailers who offer this service.</p> <p>The separate disposal of an electrical device avoids any damage to the environment or health that could result from a non-compliant disposal, and also allows the materials it is composed of to be recycled in order to save energy and resources.</p> <p>The pictogram of the wheeled container appears on the label of the instrument. It indicates the obligation for separate collection and disposal of end-of-life/out-of-use electrical and electronic equipment.</p>
---	--

c. Product weight & dimensions

Weight

Approx. 22 Kg.

Dimensions

- (W): 271 mm
- (D): 464 mm
- (H): 482-523 mm

d. Precise performances as intended by Essilor

Refractive measurement range

- Sphere (S): -30D to +22D
 - In case of VD=12)
 - Step: 0.01/0.12/0.25D
- Cylinder (C): 0 to $\pm 10D$
 - Step: 0.01/0.12/0.25D
- Axis (A): 0 to 180°
 - Step: 5°/1°unit)
- Accuracy: According to EN ISO 10342

Corneal curvature radius measurement

- Corneal curvature radius: 5.0 to 10.0 mm
 - Step: 0.01mm
- Corneal refractivity: 33.75 to 67.5D
 - However, Corneal Refractive n=1.3375
 - Step: 0.12/0.25D
- Degree of corneal astigmatism: 0 to $\pm 10D$
 - Step: 0.12/0.25D
- Axis Angle: 1 to 180°
 - Step: 5°/1°

- Peripheral measurement : $\varnothing 7.0$ mm
- Accuracy: According to EN ISO 10343

Adjustment measurement

- Measurement range: 0 ~ +5.0D

Vertex distance

- 0 mm
- 10 mm
- 12 mm
- 13.5 mm
- 15 mm

Minimum pupil diameter

- $\varnothing 2.0$ mm

PD measurement

- Measurement range: 0 mm to 85 mm
 - Step: 1 mm
- Accuracy: Within ± 1 mm

Pupil diameter measurement

- Measurement range: $\varnothing 2.0$ mm to 8.5 mm
 - Step: 0.1 mm
- Accuracy: Within ± 0.1 mm

Corneal diameter measurement

- Measurement range: $\varnothing 2$ to $\varnothing 14$ mm
 - Diagonal measurement: $\varnothing 14$ mm
- Step: 0.1 mm
- Accuracy: Within ± 0.2 mm

Printer

- The thermal line printer with auto-cutter (paper width 57 mm)

Internal monitor

- 10.4 inches color LCD monitor (TFT)

Shifting range of the sliding body

- Back/forth: ± 16 mm
- Right/left: ± 43 mm
- Up/down: ± 20 mm

Vertical adjustment range of chinrest

- ± 30 mm

e. Precise performances accuracy / function

Data output

- LAN connector
- USB-A connector
- RS-232C connector

Power source

- AC 100 to 240V
- 50/60Hz

Power rating

- 90VA

Power saving function

- OFF (switchable)
- 3 min (switchable)
- 5 min (switchable)
- 10 min (switchable)

2. Electromagnetic compatibility

AKR800 conforms to the requirements of the EMC (electromagnetic compatibility) standard. This device complies with EMC standard IEC 60601-1-2 and the expected electromagnetic environment for the entire life cycle in the home healthcare environment.

When used in hospitals, etc., except for near active HF surgical equipment and RF shielded rooms with an ME system for magnetic resonance imaging, where the intensity of electro-magnetic disturbances is high.

If there is electromagnetic interference stronger than the IEC 60601-1 test level, the following phenomena may occur as a loss / deterioration of performance due to electromagnetic interference. You may observe:

- Unreliable measurements
- Unavailable measurements
- Incorrect completion of alignment
- Incorrect data output values
- Incorrect display of patient ID



- AKR800 or the system should not be used adjacent to or stacked with other equipment. If adjacent or stacked use is necessary, AKR800 or the system should be observed to verify normal operation in the configuration in which it will be used.
- The use of the accessory, transducer or cable with the AKR800 or the system other than those specified may result in increased emission or decreased immunity of AKR800 or the system.
- Do not use equipment that emits electromagnetic waves within 30 cm (12 inch) of any part of the AKR800 or the system. It can result in reduced performance of the AKR800 or the system.

Guidance and manufacturer's declaration - electromagnetic emissions

The [AKR800] is intended for use in the electromagnetic environment specified below. The customer or user of the [AKR800] should assure that it is used in such an environment.

Emissions test	Basic EMD Standard	Compliance
Conducted and radiated RF emissions	CISPR 11	Class B, Group 1
Harmonic current distortion	IEC 61000-3-2	Class A
Voltage fluctuations and flicker	IEC 61000-3-3	Complies

It is not intended for use in aircraft and vehicle.

This device is suitable for use in all establishments, including domestic establishments and those directly connected to the public low-voltage power supply network that supplies buildings used for domestic purposes.

Cable	Connector shield	Cable shield	Ferrite core	Length [m]
Power cord	No	No	No	2.5
Cat7 LAN cable	Yes	Yes	No	Within 3
RS-232C cable	No	No	No	Within 3

Specified Multimedia Equipment

Personal computer: Compliant with CISPR 32 Class B

Guidance and manufacturer's declaration - electromagnetic immunity

The [AKR800] is intended for use in the electromagnetic environment specified below. The customer or user of the [AKR800] should assure that it is used in such an environment.

Immunity test	Basic EMC standard or test method	Test level - Home healthcare environment	Compliance level
Electrostatic discharge	IEC 61000-4-2	± 8 kV contact ± 2, 4, 8, 15 kV air	± 8kV contact ± 2, 4, 8, 15kV air
Radiated RF EM fields	IEC 61000-4-3	10 V/m ^a 80 MHz to 2.7 GHz 80% AM at 1 kHz	10V/m
Proximity fields from RF wireless communications equipment		See the table below.	
Rated power frequency magnetic fields	IEC 61000-4-8	30 A/m 50 Hz or 60 Hz	30 A/m
Proximity magnetic fields	IEC 61000-4-39	30kHz (8A/m) 134.2kHz (65A/m) 13.56MHz (7.5A/m)	30kHz (8A/m) 134.2kHz (65A/m) 13.56MHz (7.5A/m)



^a Before modulation is applied.

Recommended separation distances between portable and mobile RF communications equipment and the AKR800

The [AKR800] is intended for use in an electromagnetic environment in which radiated RF disturbances are controlled. The customer or the user of the [AKR800] can help prevent electromagnetic interference by maintaining a minimum distance between portable and mobile RF communications equipment (transmitters) and the [AKR800] as recommended below, according to the maximum output power of the communications equipment.

Test frequency (MHz)	Band ^a (MHz)	Service ^a	Modulation ^b	Max power (W)	Distance (m)	Immunity test level (V/m)	Compliance level
385	380 - 390	TETRA400	Pulse modulation ^b 18Hz	1.8	0.3	27	27
450	430 - 470	GMRS460, FRS460	FM ±5kHz deviation 1kHz sine	2	0.3	28	28
710	704 - 787	LTE Band 13, 17	Pulse modulation ^b 217Hz	0.2	0.3	9	9
745							
780							
810	800 - 960	GSM800/900, TETRA800, iDEN820, CDMA850, LTE Band 5	Pulse modulation ^b 18Hz	2	0.3	28	28
870							
930							
1720	1700 - 1990	GSM1800 ; CDMA1900 ; GSM1900 ; DECT ; LTE Band 1, 3, 4, 25 ; UMTS	Pulse modulation ^b 217Hz	2	0.3	28	28
1845							
1970							

2450	2400 - 2570	Bluetooth, WLAN, 802.11b/g/n, FRID2450, LTE Band 7	Pulse modulation ^b 217Hz	2	0.3	28	28
5240	5100 - 5800	WLAN 802.11a/n	Pulse modulation ^b 217Hz	0.2	0.3	9	9
5500							
5785							



^a For some services, only the uplink frequencies are included.

^b The carrier shall be modulated using a 50% duty cycle square wave signal.

Immunity test	Basic EMC standard	Immunity test levels - Home healthcare environment	Compliance level
Electrical fast transients/ bursts	IEC 61000-4-4	Input AC power port ± 2kV 100 kHz repetition frequency	± 2kV
		Signal input/ output unit port ±1kV 100 kHz repetition frequency	± 1kV
Surges Line-to-line	IEC 61000-4-5	± 0.5kV, ± 1kV	
Surges Line-to-ground		± 0.5kV, ± 1kV, ± 2kV	
Conducted disturbances induced by RF fields	IEC 61000-4-6	3 Vrms 0.15 MHz - 80 MHz 6 Vrms in ISM bands between 0.15 MHz and 80 MHz 80% AM at 1 kHz	3 Vrms 6Vrms in ISM bands
Voltage dips (IEC 61000-4-11:2020)	IEC 61000-4-11	0% U_T ; 0.5 cycle 0°, 45°, 90°, 135°, 180°, 225°, 270° and 315°	0% U_T ; 0.5 cycle
		0% U_T ; 1 cycle and 70% U_T ; 25 cycles Single phase: 0°	0% U_T ; 1 cycle 70% U_T ; 25 cycles
Voltage interruptions		0% U_T ; 250 cycles	0% U_T ; 250 cycles



U_T is the AC supply voltage before applying inspection level.



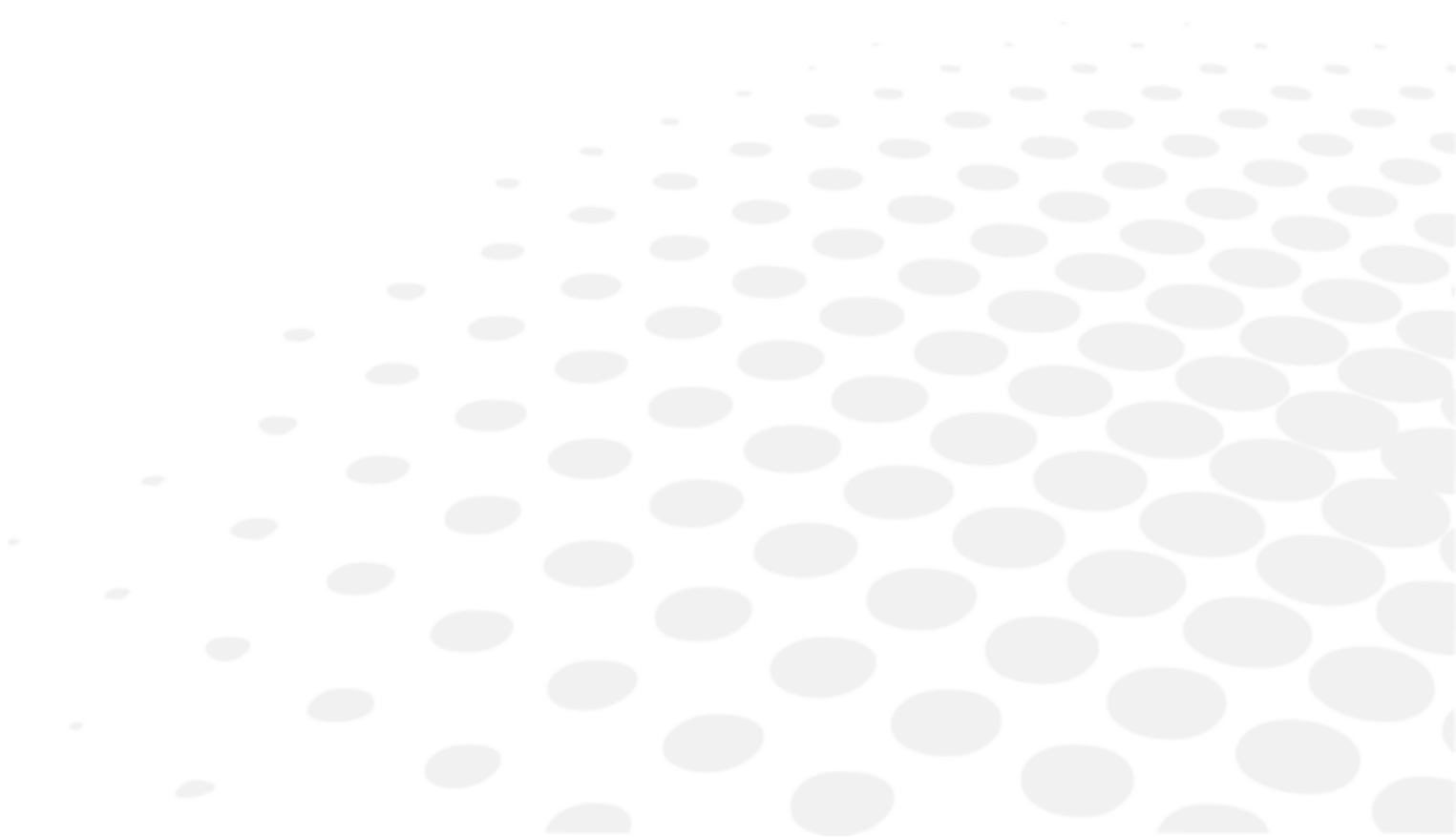

3. IT requirements

Please refer to section 2 of chapter III for detailed information.















XI. SYMBOL EXPLANATION



1. On the document





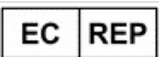









SYMBOL	DESCRIPTION
	Caution: a hazardous situation that, if not avoided, could result in minor or moderate injury.
	Warning: a hazardous situation that, if not avoided, could result in death or serious injury.
	Important and/or useful additional information to learn relating to the text in this manual.
	Tips: practical advice.

2. On the device

SYMBOL	DESCRIPTION
	General warning sign
	Obligation to refer to the operation manual
	Serial No.
	Catalog number
	Unique Device Identifier
	OFF = Turned-off (power supply disconnected to the mains)
	ON = Turned-on (power supply connected to the mains)
	Applied, type B parts.
	Manufacturer
	Country of manufacture (JP: JAPAN) Manufacturing date is indicated below in the format YYYY-MM
	CE mark
	Medical device
	Do not mix with regular waste. (2012/19/EU electrical and electronic equipment Waste Directive (WEEE))
	To indicate on the rating plate that the equipment is suitable for alternating current only; to identify relevant terminals.
	Protective earth (ground)
	Authorized representative in the European community

3. On the packaging

For proper handling, storage and transport requirement.

SYMBOL	DESCRIPTION
	Symbol for Compliant with CE marking i.e. with applicable European directives
	Obligation to refer to the operation manual
	Stepping prohibited
	Packaging unit To indicate the number of pieces in the package
	Serial No.
	Catalog number
	Unique Device Identifier
	Manufacturer
	Country of manufacture (JP: JAPAN) Manufacturing date is indicated below in the format YYYY-MM
	Medical device
	Keep dry
	This way up
	Fragile
	Limiting number of stages loading (up to 2 stages)
	Indicate the thermal limits to which the medical device can be exposed in complete safety
	Indicate the humidity limits to which the medical device can be exposed in complete safety
	Indicate the limits of atmospheric pressure to which the medical device can be exposed in complete safety

XII. EXCLUSION OF LIABILITY

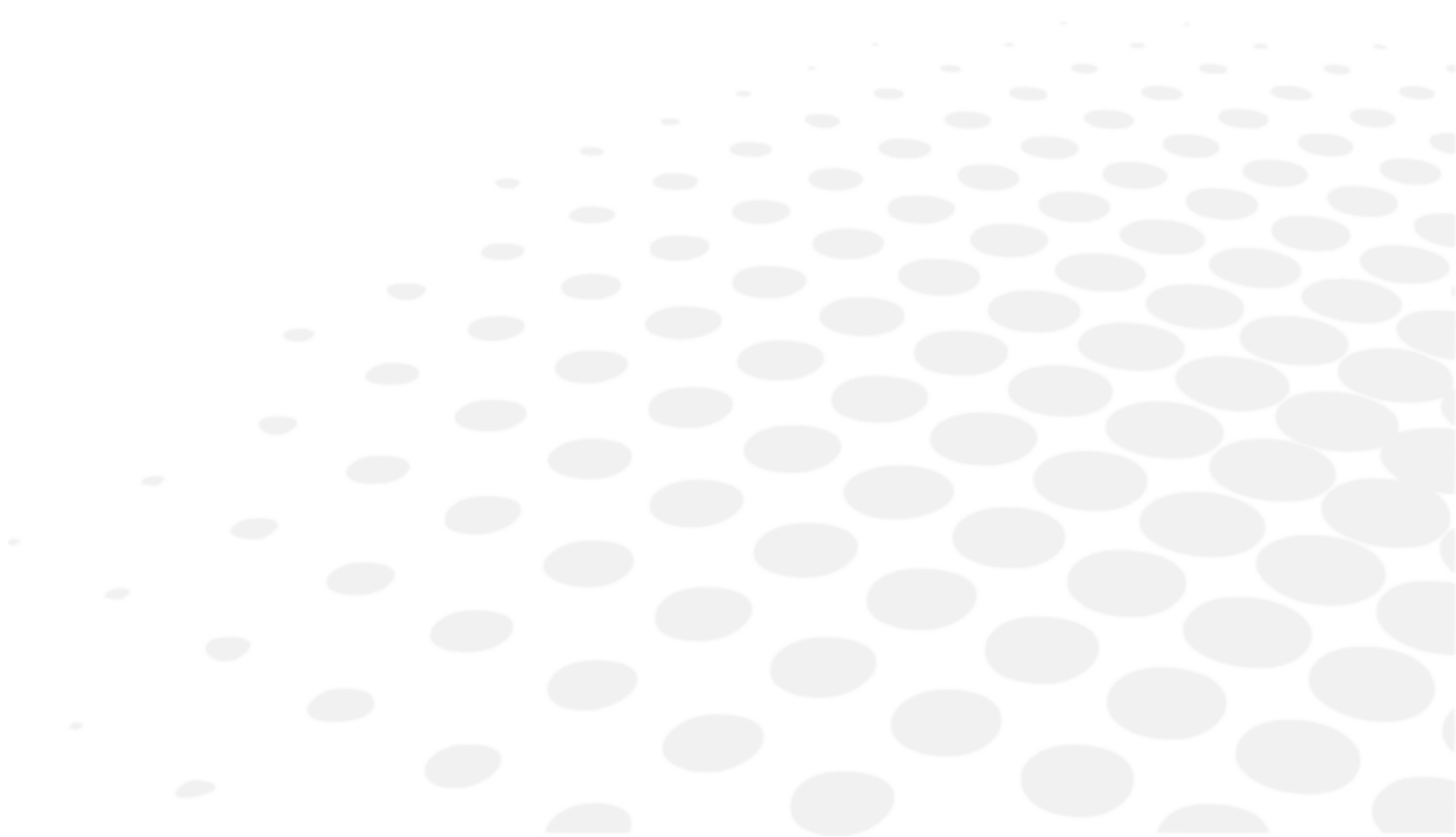

The product shall be used in compliance with the applicable laws and regulations, by qualified, professional users. The product must be installed and used according to the instructions provided in the present user manual and to any written direction or recommendation provided by Essilor (the “documentation”).

Essilor reserves the right to revise the documentation and to make changes in its content from time to time. Preventive and corrective maintenance (including regular calibration, if necessary according to the documentation) shall be performed in accordance with the documentation.

Any product warranty offered by Essilor is contingent upon use of the product in accordance with the documentation and with the product's intended use and does not cover products that were modified without Essilor's prior written approval or repaired by a third party not approved by Essilor, nor to products that were subjected to physical, chemical or electrical stress that the products were not originally designed for.

Essilor shall not be held liable for any damages suffered by the user of the product, the product, or any third party, resulting from any user's non-compliance to the present section.

If the product offers a connectivity function, the user shall be sole responsible for:

- selecting, obtaining and maintaining all required internet access and telecommunications at its own costs; and
- adopting and maintaining procedures and measures to protect its workstations, hardware and software, other than the Product, including against any virus or intrusion

XIII. QR CODE

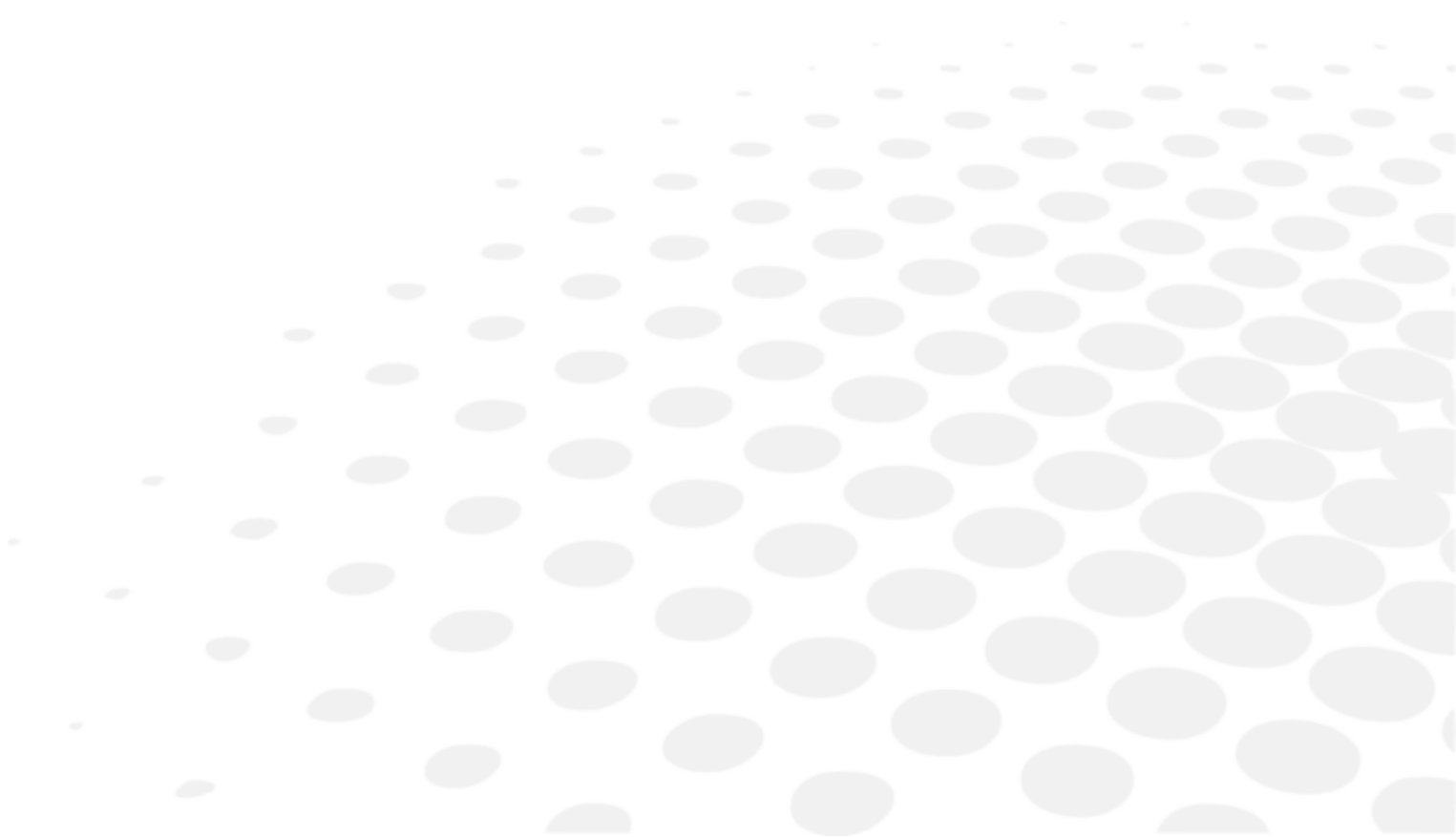

The latest version of the user manual in the appropriate language is available on a web space. Upon request, a paper version can be provided for free.

en The complete user manual is available on a web space in PDF format. To access it, please scan the QR code below using a dedicated tool or application. Please make sure that your device is suitable and has an appropriate software to display the electronic Instructions for use.

fr Le manuel utilisateur complet est disponible sur un espace web au format PDF. Pour y accéder, veuillez scanner le QR code ci-dessous à l'aide d'un outil ou d'une application dédié(e). Veuillez vous assurer que votre appareil est compatible et dispose d'un logiciel approprié pour afficher le manuel électronique.

ar لتمكن من الوصول إليه، يُرجى مسح رمز الاستجابة السريعة PDF دليل المستخدم الكامل متوفر من خلال موقع الويب بصيغة أدناه باستخدام أداة أو تطبيق مخصص لذلك. يُرجى التأكد من أن جهازك مناسب ويحتوي على برنامج مناسب لعرض التعليمات الإلكترونية الخاصة بالاستخدام.

be Поўная інструкцыя карыстальніка даступна ў інтэрнэт-прасторы у фармаце PDF. Каб атрымаць да яе доступ, адсканіруйце QR-код ніжэй пры дапамозе спецыяльнага сродку або праграмы. Калі ласка, упэўніцеся, што ваша прылада прыдатная для паказу электроннай Інструкцыі па карыстанню і што на ёй усталявана адпаведнае праграмае забеспячэнне.

bg Пълното ръководство за потребителя е достъпно в уеб пространството. За да получите достъп до него, моля, сканирайте QR кода по-долу, като използвате специален инструмент или приложение. Моля, уверете се, че вашето устройство е подходящо и разполага с подходящ софтуер за преглед на електронните Инструкции за употреба.

cs Kompletní uživatelský návod je k dispozici na webovém prostoru ve formátu PDF. Chcete-li k němu získat přístup, naskenujte prosím níže uvedený QR kód pomocí speciálního nástroje nebo aplikace. Ujistěte se prosím, že používáte vhodné zařízení, které má vhodný software pro zobrazení elektronického uživatelského návodu.

da Den komplette brugervejledning er tilgængelig på et webområde i PDF-format. For at få adgang til den skal du scanne QR-koden nedenfor ved hjælp af et dedikeret værktøj eller program. Sørg for, at din enhed er egnet og har en passende software til at vise de elektroniske brugsanvisninger.

de Die vollständige Bedienungsanleitung ist auf einem Webspace im PDF-Format verfügbar. Für den Zugriff scannen Sie bitte den untenstehenden QR-Code mit einem speziellen Tool oder einer Anwendung. Bitte vergewissern Sie sich, dass Ihr Gerät für die Anzeige der elektronischen Gebrauchsanweisungen geeignet ist und über eine entsprechende Software verfügt.

el Το πλήρες εγχειρίδιο χρήσης είναι διαθέσιμο σε έναν ιστοχώρο σε μορφή PDF. Για να αποκτήσετε πρόσβαση σε αυτό, σκανάρετε τον κωδικό QR παρακάτω χρησιμοποιώντας ένα ειδικό εργαλείο ή εφαρμογή. Βεβαιωθείτε ότι η συσκευή σας είναι κατάλληλη και έχει το κατάλληλο λογισμικό για την προβολή των ηλεκτρονικών οδηγιών χρήσης.

es El manual de uso completo está disponible en un espacio web. en formato PDF. Para acceder a él, escanee el código QR debajo utilizando una herramienta o aplicación dedicada. Asegúrese de que su dispositivo sea adecuado y tenga el software apropiado para mostrar las Instrucciones de uso electrónicas.

et Täielik kasutusjuhend on saadaval veebis PDF-vormingus. Juurdepääsuks palun skannige allolevat QR-koodi, kasutades selleks vastavat tööriista või rakendust. Veenduge, et teie seade sobib ja et selles on elektroonilise kasutusjuhendi kuvamiseks sobiv tarkvara.

fi Täysi käyttöopas on saatavana verkosta PDF-muodossa. Saat pääsyn siihen skannaamalla alla olevan QR-koodin käyttäen siihen tarkoitettu työkalua tai sovellusta. Varmista, että laitteesi on sopiva ja sisältää asianmukaisen ohjelmiston sähköisten käyttöohjeiden esittämiseen.

he למטה באמצעות כלי או QR-כדי לגשת אליו, יש לסרוק את קוד ה PDF המדריך המלא למשתמש זמין באתר אינטרנט בפורמט אפליקציה ייעודיים. חשוב לוודא שהמכשיר שלך מתאים ובעל תוכנה מתאימה להצגת הוראות השימוש האלקטרוניות.

hr Potpun korisnički priručnik dostupan je na mrežnom prostoru u PDF formatu. Da biste mu pristupili, skenirajte QR kod u nastavku pomoću odgovarajućeg alata ili aplikacije. Provjerite je li vaš uređaj prikladan i ima li odgovarajući softver za prikaz elektroničkih uputa za upotrebu.

- hu A teljes felhasználói kézikönyv elérhető az interneten PDF formátumban. Eléréséhez olvassa be az alábbi QR-kódot egy erre szolgáló eszközzel vagy alkalmazással. Ellenőrizze, hogy eszköze képes és rendelkezik a megfelelő szoftverrel az elektronikus használati útmutató megjelenítésére.
- id Panduan pengguna lengkap tersedia di ruang web dalam format PDF. Untuk mengaksesnya, silakan pindai kode QR di bawah ini menggunakan alat atau aplikasi khusus. Pastikan peranti Anda sesuai dan memiliki perangkat lunak yang layak untuk menampilkan petunjuk penggunaan elektronik.
- it Il manuale utente completo è disponibile in formato PDF su uno spazio Web. Per accedervi, leggere il codice QR sottostante mediante un apposito strumento o un'applicazione dedicata. Assicurarsi che il dispositivo sia adatto e che disponga di un software appropriato per visualizzare le istruzioni per l'uso in formato elettronico.
- ja 完全なユーザーマニュアルは、PDF形式でウェブスペースから入手できます。アクセスするには、専用のツールまたはアプリケーションを使用して、以下のQRコードをスキャンしてください。お使いのデバイスが適切であり、電子説明書を表示する適切なソフトウェアがインストールされていることを確認してください。
- ko 전체 사용 설명서는 웹 공간에 PDF 형식으로 있습니다. 이 설명서에 액세스하려면, 전용 도구 또는 앱을 사용하여 아래 QR 코드를 스캔하십시오. 사용자의 기기가 적합하고 전자적인 사용 설명서를 표시할 수 있는 적절한 소프트웨어가 있는지 확인하십시오.
- lt Išsamaus naudotojo vadovo PDF formatu ieškokite interneto svetainėje. Kad jį atvertumėte, specialiu įrankiu arba programėle nuskaitykite toliau pateiktą QR kodą. Įsitinkite, kad jūsų įrenginys yra tinkamas ir turi tinkamą programinę įrangą elektroninėms naudojimui instrukcijoms rodyti.
- lv Pilnā lietotāja instrukcija ir pieejama tīmeklī PDF formātā. Lai tai piekļūtu, lūdzu, noskenējiet tālāk redzamo kvadrātkodu, izmantojot tam paredzētu rīku vai lietojumprogrammu. Lūdzu, pārliecinieties, vai jūsu ierīce ir piemērota un vai tai ir atbilstoša programmatūra elektroniskās lietotāja instrukcijas attēlošanai.
- ms Manual pengguna yang lengkap boleh didapati di ruang laman dalam format PDF. Untuk mengaksesnya, sila imbas kod QR di bawah menggunakan alat atau aplikasi khusus. Sila pastikan yang peranti anda adalah serasi dan mempunyai perisian yang sesuai untuk memaparkan Arahan elektronik untuk tujuan penggunaan.
- mt Il-manwal tal-utent s'hih huwa disponibbli fuq il-web f'format PDF. Biex ta'cessah, jekk jogħġbok skennja l-kodiċi QR t'hawn taht permezz ta' għodda jew applikazzjoni apposta. Jekk jogħġbok żgura li l-apparat huwa xieraq u għandu s-software adattat biex juri l-Istruzzjonijiet għall-Użu elettronici.
- nl De volledige gebruikershandleiding is in PDF-formaat beschikbaar op een website. U kunt de handleiding bereiken door de QR-code hiernaast te scannen met een geschikte applicatie. Uw apparaat moet geschikt zijn en over de juiste software beschikken om de elektronische gebruiksaanwijzing weer te geven.
- no Den komplette brukerhåndboken er tilgjengelig på et webhotell i PDF-format. For å få tilgang til den, skann QR-koden nedenfor ved hjelp av et dedikert verktøy eller applikasjon. Sørg for at enheten din er egnet og har en passende programvare for å vise den elektroniske bruksanvisningen.
- pl Kompletna instrukcja użytkownika jest dostępna na stronie internetowej w formacie PDF. Aby uzyskać dostęp, zeskanuj poniższy kod QR przy użyciu dedykowanego narzędzia lub aplikacji. Upewnij się, że urządzenie jest zgodne i wyposażone w odpowiednie oprogramowanie pozwalające wyświetlać elektroniczną instrukcję obsługi.
- pt O manual do utilizador completo está disponível num espaço online no formato PDF. Para aceder a este, queira digitalizar o QR Code abaixo usando uma ferramenta ou uma aplicação dedicada. Certifique-se de que o seu dispositivo é compatível e possui um software apropriado para exibir as instruções eletrónicas de utilização.
- pt (brazil) O manual do usuário completo está disponível em um espaço online no formato PDF. Para acessar a este, por favor, digitalizar o QR Code abaixo usando uma ferramenta ou um aplicativo dedicado. Seu dispositivo deve ser compatível e possuir um software apropriado para exibir as instruções eletrônicas de utilização.
- ro Manualul de utilizare complet este disponibil online în format PDF. Pentru a-l accesa, scanați codul QR de mai jos folosind un instrument sau o aplicație dedicată. Asigurați-vă că dispozitivul dumneavoastră este potrivit și are un software adecvat pentru afișarea Instrucțiunilor de utilizare în format electronic.
- ru Полное руководство пользователя доступно в интернет-пространстве в формате PDF. Чтобы получить к нему доступ, отсканируйте QR-код ниже с помощью специального инструмента или приложения. Убедитесь, что

ваше устройство подходит и имеет соответствующее программное обеспечение для отображения электронных инструкций по эксплуатации.

sk Celý používateľský manuál je dostupný vo webovom priestore vo formáte PDF. Ak chcete získať prístup, naskenujte nižšie uvedený QR kód pomocou špeciálneho nástroja alebo aplikácie. Uistite sa, že máte vhodné zariadenie s vhodným softvérom na zobrazenie elektronického návodu na použitie.

sl Celoten uporabniški priročnik je na voljo kot dokument PDF na spletnem mestu. Za dostop optično preberite spodnjo kodo QR z namenskim orodjem ali aplikacijo. Prepričajte se, da je vaša naprava primerna in ima ustrezno programsko opremo za prikaz elektronskih navodil za uporabo.

sr Kompletno uputstvo za korisnike je dostupno na veb prostoru u PDF formatu. Da biste mu pristupili, skenirajte QR kôd u nastavku pomoću namenske alatke ili aplikacije. Proverite da je vaš uređaj odgovarajući i da li ima potreban softver za prikaz elektronskog Uputstva za upotrebu.

sv Den fullständiga bruksanvisningen finns tillgänglig på ett webbutrymme i PDF-format. För att komma åt den, vänligen skanna QR-koden nedan med ett dedikerat verktyg eller program. Se till att din enhet är lämplig och har en passande programvara för att visa de elektroniska användningsinstruktionerna.

th สามารถรับคู่มือผู้ใช้ฉบับสมบูรณ์ในรูปแบบ PDF ได้จากบนเว็บไซต์ โดยในการเข้าถึง โปรดสแกนคิวอาร์โค้ดด้านล่างด้วยเครื่องมือหรือแอปพลิเคชันเฉพาะ โปรดตรวจสอบให้แน่ใจว่าอุปกรณ์ของคุณนั้นเหมาะสม และมีซอฟต์แวร์ที่สามารถใช้ในการแสดงคำแนะนำการใช้งานอิเล็กทรอนิกส์ได้อย่างถูกต้อง

tr Kullanım kılavuzunun tamamı web alanında, PDF formatında mevcuttur. Buna erişmek için lütfen uygun bir araç veya uygulama kullanarak aşağıdaki QR kodunu okutun. Lütfen cihazınızın uyumlu ve elektronik kullanım talimatlarını görüntülemek için uygun bir yazılıma sahip olduğundan emin olun.

uk Повна версія посібника користувача доступна в інтернеті в форматі PDF. Щоб отримати до нього доступ, скануйте QR-код нижче за допомогою спеціального додатку. Для перегляду електронного посібника користувача на вашому пристрої він повинен мати відповідні характеристики та програмне забезпечення.

vi Hướng dẫn sử dụng đầy đủ có sẵn trên không gian web ở định dạng PDF. Để truy cập, vui lòng quét mã QR bên dưới bằng công cụ chuyên dụng hoặc bằng ứng dụng. Vui lòng đảm bảo rằng thiết bị của bạn phù hợp và có phần mềm phù hợp để hiển thị Hướng dẫn sử dụng điện tử

zh 完整的操作手册以 PDF 格式在网络上提供。如需获取，请使用专门的工具或应用程序扫描下方二维码。请确保您的设备适用并安装有相应的软件，能够显示电子版使用说明。



XIV. CONTACT INFORMATION

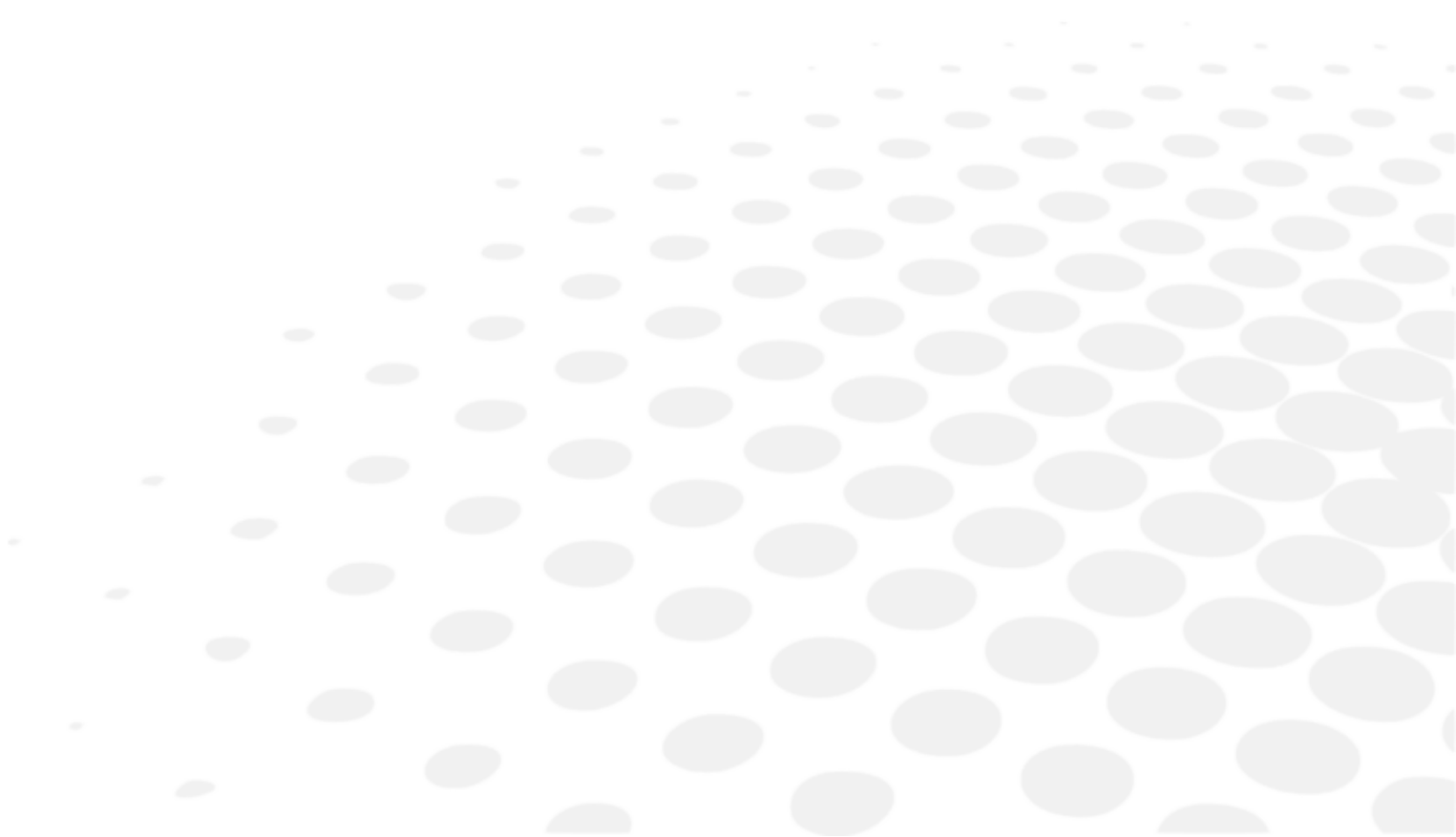

If the instrument appears malfunctioning, it is highly recommended to check the instrument according to the troubleshooting procedure of this manual.

If any problem persists or the instrument is damaged or malfunctioning or it is mentioned to contact your local distributor, please follow the steps below.

- Please contact the local distributor in your province or country at first. All information is available on www.essilor-instruments.com in the "Contact" section.
- If the product has been provided with electronic instruction and you need a paper format, please contact your local distributor.
- If any serious incident occurred in relation to the device, report it to essilor-instruments-vigilance@essilor.com and to the local competent authority for medical devices.
- Before calling to the local distributor, please be sure to check Model and Serial Numbers.
- The serial number is unique to this unit and is accessible on the product. It is recommended to fill up the following table as soon as you purchase our product.
- Please keep this manual as a permanent record of your purchase and keep your purchase receipt as your proof of purchase.

Date of Purchase:

Dealer's Name:

Dealer address:

Dealer Phone No.:

Model No.:

Serial No.:



Essilor International
147, rue de Paris – 94220 Charenton-le-Pont France
www.essilor.com

